

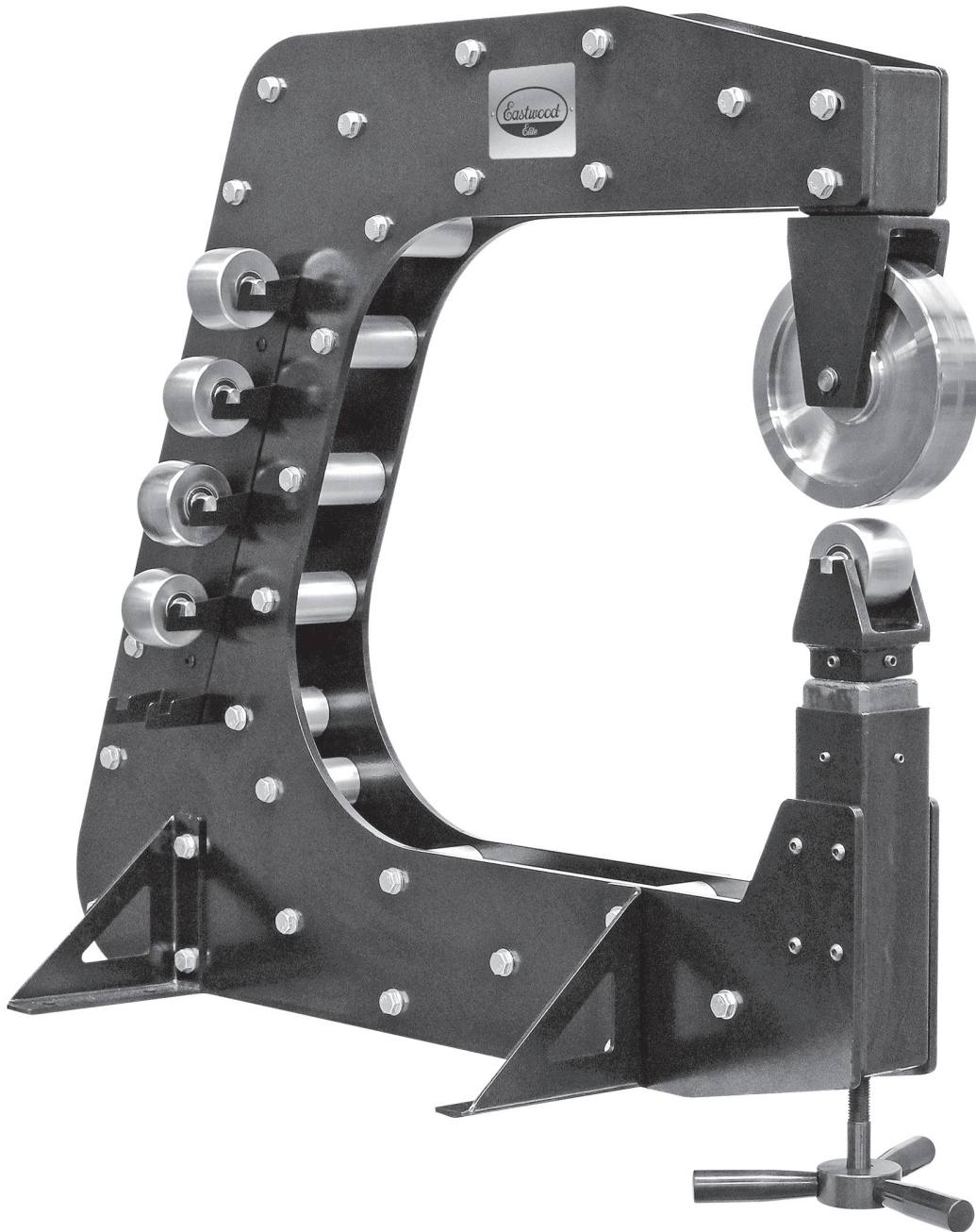

Item #64646

LARGE FRAME ENGLISH WHEEL ASSEMBLY AND OPERATING INSTRUCTIONS



The **EASTWOOD ELITE LARGE FRAME ENGLISH WHEEL** was developed by Eastwood to be a cost effective, rigid, and modular wheeling solution for the hobbyist or professional. The cantilever frame design is evolved from the successful Mini English Wheel to provide a generous 24.9" [633mm] throat depth in a horizontal plane and up to 27.4" [697mm] at an angular panel working plane. Fully indexable Upper Wheel and Lower Anvil positions allow working from the front of the Frame or 90° to either side.

CONTENTS

- (1) English Wheel Assembly [A], Includes:
 - (1) Wheel Yoke Assembly [B], with 8" [203mm] Diameter Wheel
 - (1) Anvil Yoke Assembly [C], with 5" [127mm] Radius Anvil (installed)
- (2) Mounting Bracket, Type 1 [D]
- (2) Mounting Bracket, Type 2 [E]
- (1) Hub and Jackscrew Assembly [F]
- (3) Jackscrew Handles [G]
- (1) 3" [76mm] Radius Anvil [H]
- (1) 4" [102mm] Radius Anvil [J]
- (1) 6" [152mm] Radius Anvil [K]
- (1) 8" [203mm] Radius Anvil [L]
- (1) Anvil Rack [M]

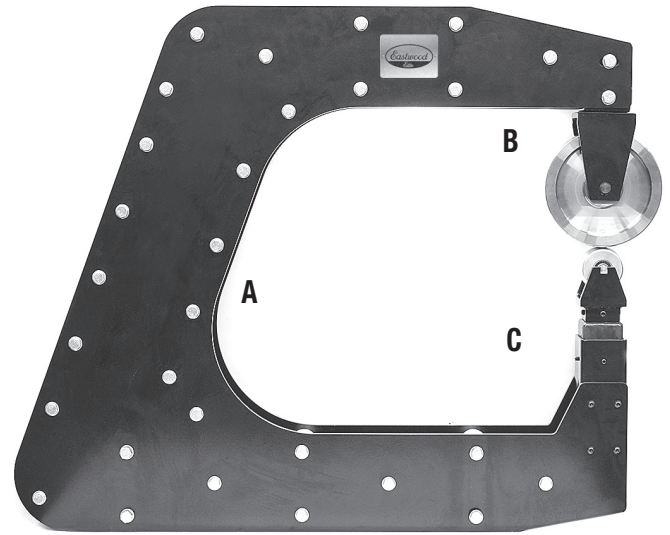

SPECIFICATIONS

- Wheel Diameter:** 8.00" [203mm]
- Anvil Diameter:** 3.25" [82mm]
- Throat Depth (horizontal):** 24.9" [191mm]
 Note: Up to 27.4" [697mm] when working a panel in an angular plane
- Maximum Material Working Thickness:** Steel: 16 Gauge, Aluminum: 14 Gauge
- Maximum Panel Width (working from center):** 48" [1220mm]

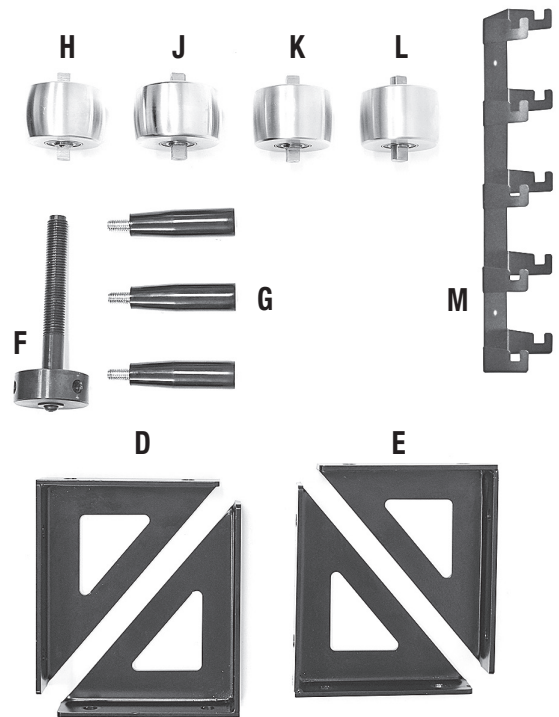

SAFETY INFORMATION

The following explanations are displayed in this manual, on the labeling, and on all other information provided with this product:

⚠ DANGER

DANGER indicates a hazardous situation which, if not avoided, will result in death or serious injury.

⚠ WARNING

WARNING indicates a hazardous situation which, if not avoided, could result in death or serious injury.

⚠ CAUTION

CAUTION indicates a hazardous situation which, if not avoided, could result in minor or moderate injury.

⚠ NOTICE

NOTICE is used to address practices not related to personal injury.



⚠ READ INSTRUCTIONS

- Thoroughly read and understand this manual before using.
- Save for future reference.



⚠ WARNING PINCH AND CRUSH HAZARD!

- The Eastwood Elite Large Frame English Wheel is a heavy assembly 265 lbs. [120 kg] which can cause serious injuries if allowed to drop. The use of a Hoist or similar mechanical lifting equipment capable of lifting a minimum of 300 lbs. [136 kg] is required. Lifting straps rated for a minimum of 300 lbs. [136 kg] are required (not included).
- Obtaining the assistance of a capable helper during assembly is strongly recommended
- Avoid pinching hands while handling parts and during assembly. The use of thick, well-fitting work gloves is strongly recommended.
- The wearing of approved safety shoes is strongly recommended when uncrating, assembling, and operating the Eastwood Elite Large Frame English Wheel. Keep fingers and hands away from moving parts when operating.



⚠ WARNING CUT HAZARD!

- Handling sharp metal can cause serious cuts. Wear thick, well-fitting work gloves to prevent cuts from handling sharp metal.



⚠ WARNING EYE INJURY HAZARD!

- Metal particles can be ejected from the metal surface when rolling. Sheet metal edges and corners are sharp and can injure eyes. Always wear ANSI approved eye protection when operating this tool.



⚠ WARNING

- Before beginning ANY work with the Eastwood Elite Large Frame English Wheel, it is necessary that it be fastened to a sturdy work-bench anchored to the floor or wall.
- Some minor physical force and awkward positions may be applied to the workpiece while using The Eastwood Elite Large Frame English Wheel. Failure to ensure proper footing can quickly result in a fall which could inflict serious personal injury or property damage. Always work in a clean, uncluttered environment.
- Make sure there is sufficient working room around the tool to allow for safe handling of various sizes of metal.

LARGE FRAME ENGLISH WHEEL COMPONENT IDENTIFICATION; FIG 1

FIG. 1

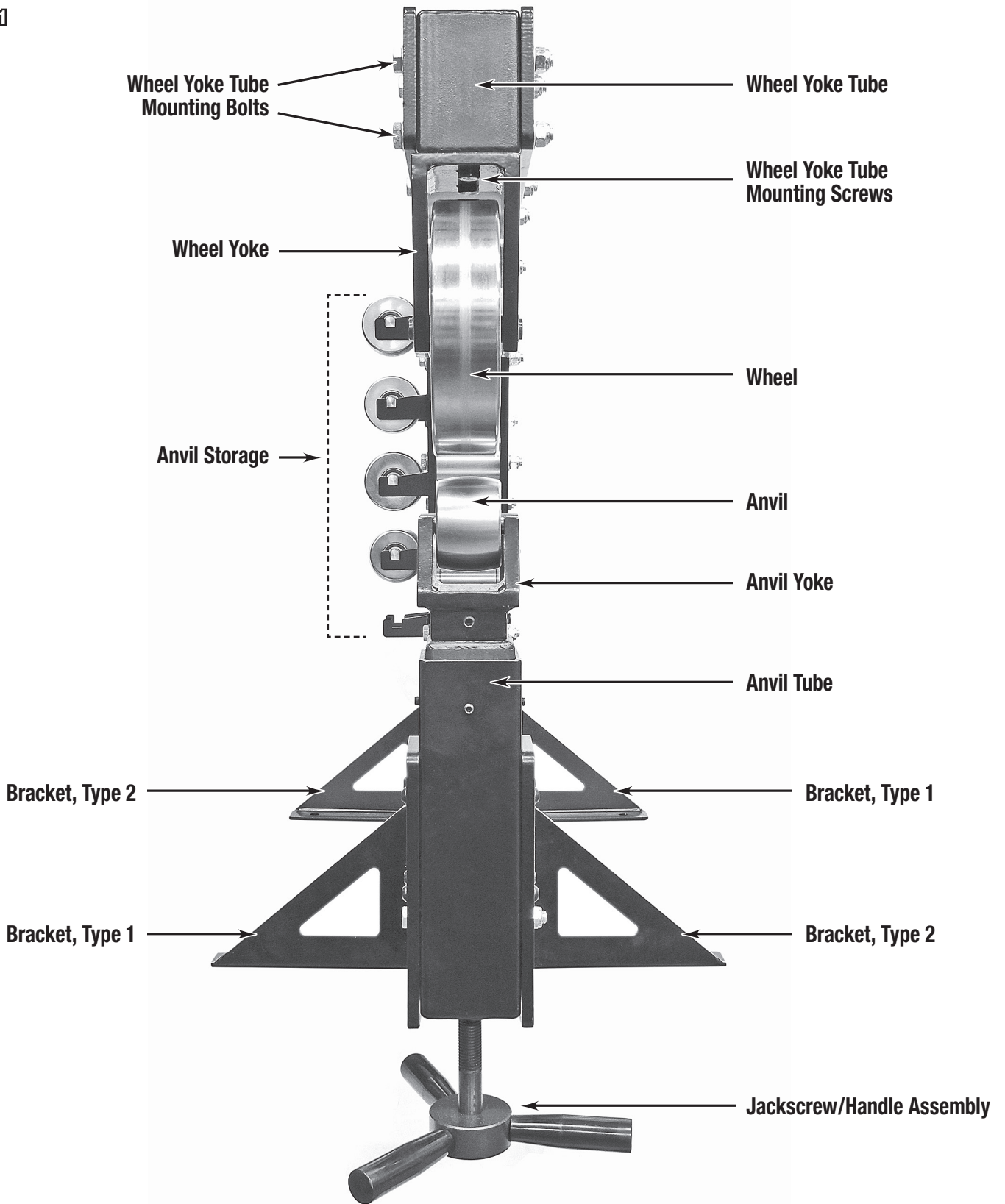

UNCRATING

- Remove the top lid from the crate.
- With the lid removed, the components can be accessed. Remove all packaging insulation and boxed components.
- Remove the wooden blocks and foam pinning the English Wheel in place to facilitate easy removal.

⚠ WARNING PINCH AND CRUSH HAZARD!

- The Eastwood Elite Large Frame English Wheel is a heavy assembly 265 lbs. [120 kg] which can cause serious injuries if allowed to drop. The use of a Hoist or similar mechanical lifting equipment capable of lifting a minimum of 300 lbs. [136 kg] is required. Lifting straps rated for a minimum of 300 lbs. [136 kg] are required (not included).
- Obtaining the assistance of a capable helper during assembly is strongly recommended
- Avoid pinching hands while handling parts and during assembly. The use of thick, well-fitting work gloves is strongly recommended.
- The wearing of approved safety shoes is strongly recommended when uncrating, assembling, and operating the Eastwood Elite Large Frame English Wheel. Keep fingers and hands away from moving parts when operating.

- To lift the English Wheel, utilization of an engine crane or other lifting device is highly recommended. Loop a strap around the top of the Frame biased towards the rear and lift (FIG 2).
- Lift the English Wheel upright and carefully set it down in the crate. Reposition the lifting strap around the Frame Spacer as shown (FIG 3).
- Lift and set the English Wheel in the desired mounting location. Leave the lifting equipment in place to assist attachment of the mount brackets (FIG 4).

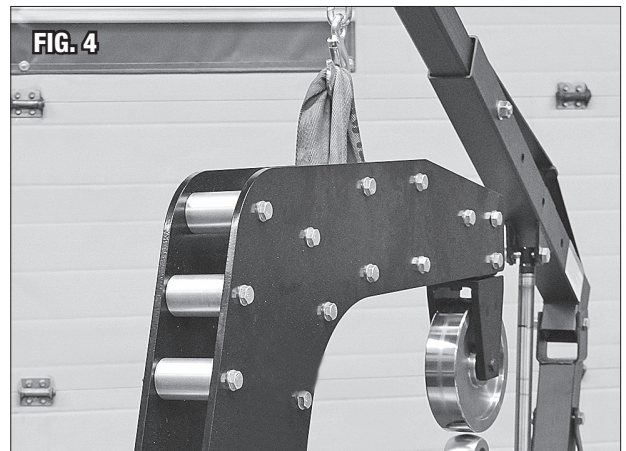
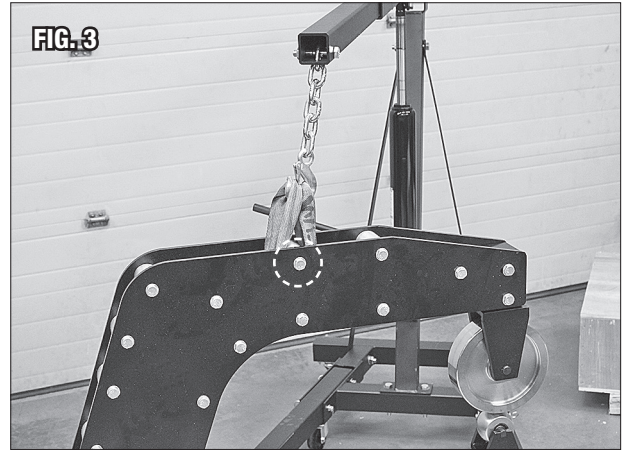
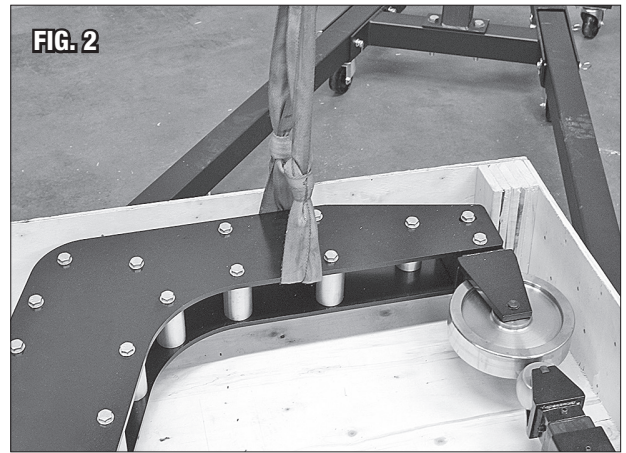

SET UP

- With the English Wheel positioned on the mounting surface (**FIG 5**), unbox the Mounting Brackets.
NOTE: There are two different Mounting Brackets supplied with the Eastwood Elite Large Frame English Wheel. Refer to **FIG. 1** for recommended Bracket positions.
- Remove the loose, preinstalled hardware in the bracket locations. Hold the Mounting Brackets in place and slide the bolt through the brackets, then refasten the nut and tighten to 40 foot-pounds (55 Nm) (**FIG 5**).
- If mounting on a tabletop, bring the front of the mounting brackets flush with the table edge (**FIG 6**) for the best wheeling experience and clearance of the Jack-screw. If you wish to wheel with the anvils perpendicular to the frame frequently, we recommend mounting it at a corner.

⚠ WARNING ELECTRICAL SHOCK HAZARD!

When drilling a table ensure there are no electrical wires in the path of the drill bit. Drilling into electrical wires could result in severe injury or death.

- To avoid possible personal injury or tool damage, it is required to mount the frame securely to the work surface or frame before moving forward. 7/16" [12mm] through bolts or lag screws with washers should be used.

⚠ WARNING

- Before beginning ANY work with the Eastwood Elite Large Frame English Wheel, it is necessary that it be fastened to a sturdy workbench anchored to the floor or wall.
- Some minor physical force and awkward positions may be applied to the workpiece while using The Eastwood Elite Large Frame English Wheel. Failure to ensure proper footing can quickly result in a fall which could inflict serious personal injury or property damage. Always work in a clean, uncluttered environment.
- Make sure there is sufficient working room around the tool to allow for safe handling of various sizes of metal.

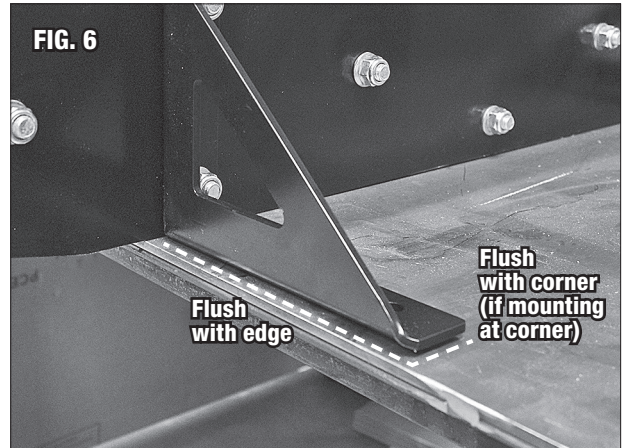
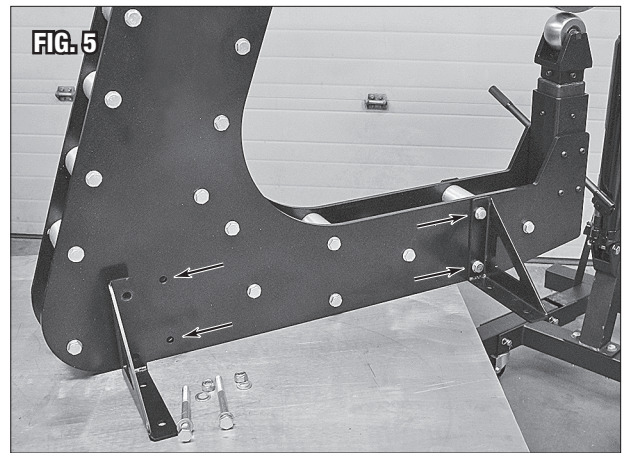

ASSEMBLY

- Unbox the Hub and Jackscrew Assembly [F] and three Jackscrew Handles [G]. Assemble the jackscrew by threading the handles into the hub (FIG 7).
- Apply a good quality, medium bodied chassis grease to the Jackscrew threads for smoothest operation.
- Thread the Jackscrew into the bottom of the Frame until it begins to engage the bottom of the Anvil Tube (FIG 8).
- Install the Anvil Rack [M] to the left side of the English Wheel using the hardware pre-installed on the Anvil Rack (FIG 9).
- Unbox the additional Anvils and stow them on the Anvil Rack (FIG 9).

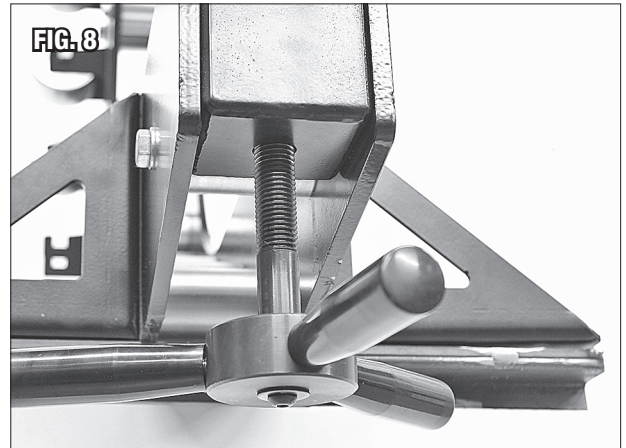

WHEEL TO ANVIL ALIGNMENT

- For best results, Eastwood recommends verifying alignment of the Wheel and Anvil with a straight edge before use.
To do so: Begin by loosening the Anvil Tube set screws (**FIG 10**) and raising the Anvil to just below the Wheel by turning the Jackscrew.
- Check alignment of Anvil to the Anvil Tube with the straight edge (**FIG 11**). If necessary, loosen the Anvil Yoke set screws and rotate into alignment.
- Verify, visually, the Wheel Yoke and Wheel are centered left to right and parallel with the Frame (**FIG 12**). If adjustment is needed, the Wheel Yoke is slotted for left to right adjustment. Loosen the Wheel Yoke Mounting Screws (**FIG 13**) to adjust.
- Raise the Anvil until it just touches the Wheel by turning the Jackscrew.

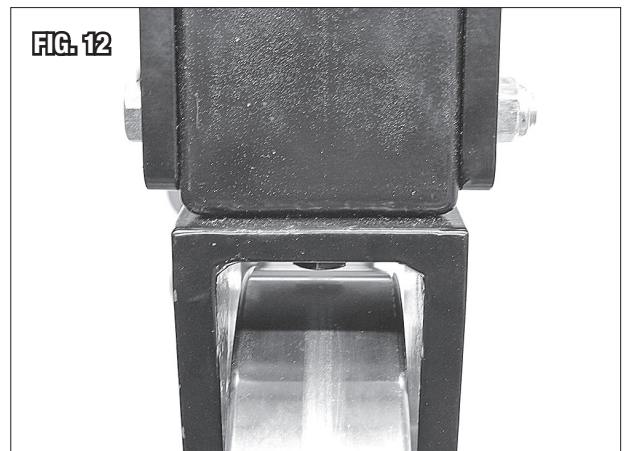
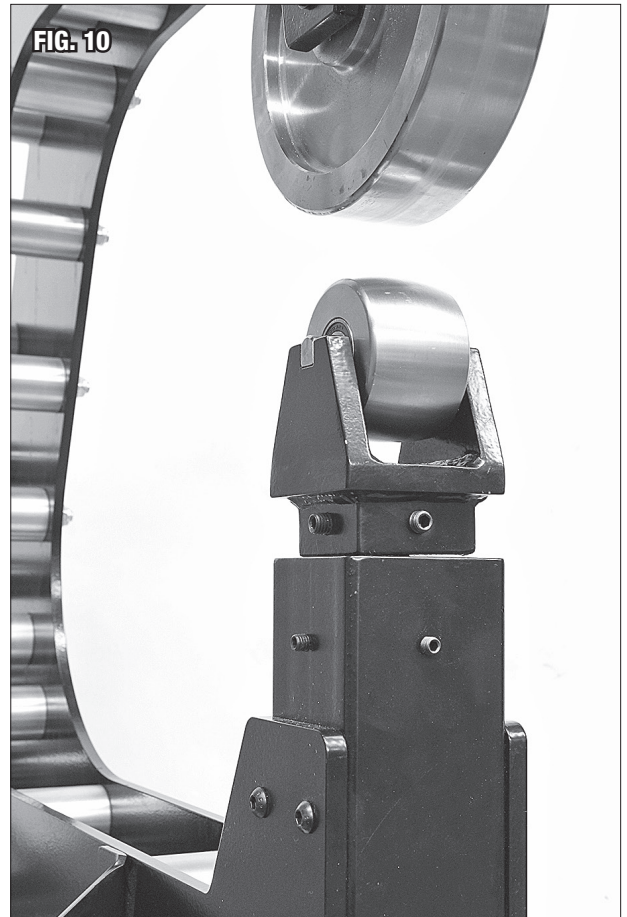

- Utilizing a combination square, verify alignment of the centerline of the Wheel Axle to the Anvil Axle (**FIG 14**). If adjustment is necessary, Loosen the Wheel Yoke Tube Mounting Bolts so that it can be pivoted in the slot. Retighten to 40 foot-pounds (55 Nm) when aligned.
- Lay the straight edge at a diagonal across the Wheel and the Anvil (**FIG 15**) in both directions (**FIG 16**).
- The straight edge, ideally, should lay flush with both Wheel and Anvil faces. However, a 1/8" [3mm] gap will not affect wheeling. If adjustment is necessary:
 - Turn the Anvil Tube set screws in or out from opposite directions as needed to move the Anvil and Wheel into alignment.
 - With the alignment verified, the Anvil Tube set screws can be lightly tightened.

▲ NOTICE

DO NOT over tighten the Anvil Tube Screws as the Anvil Tube needs to be able to move up and down smoothly.

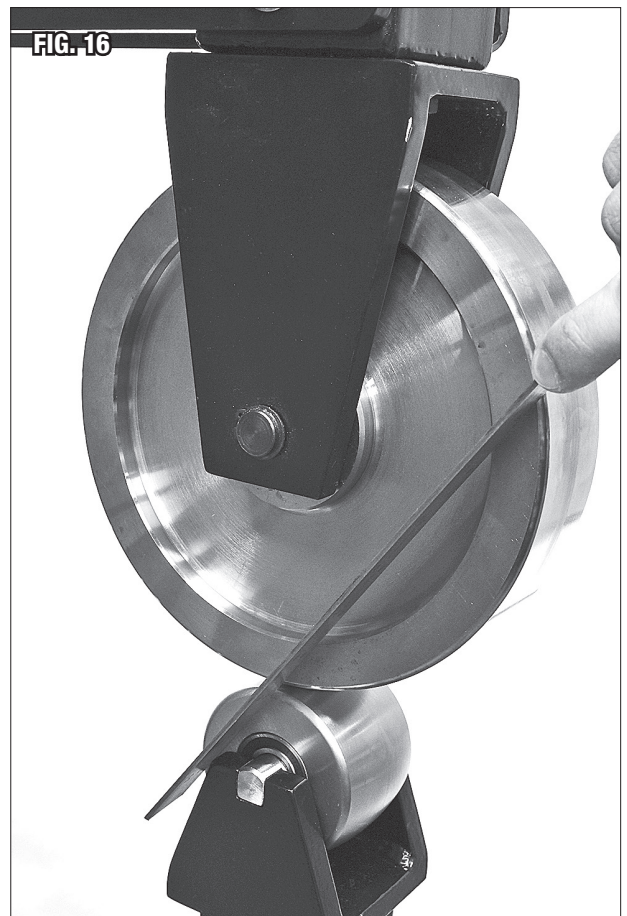
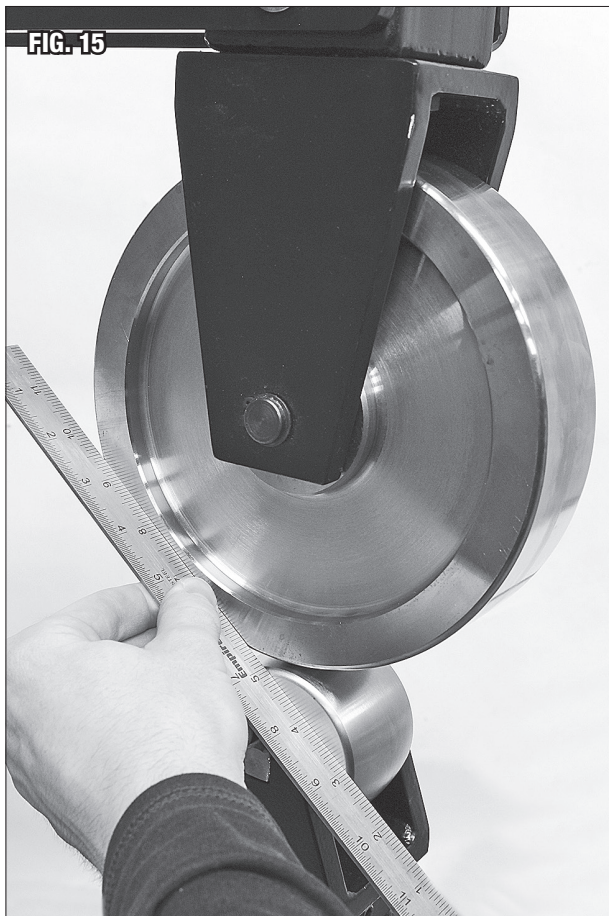
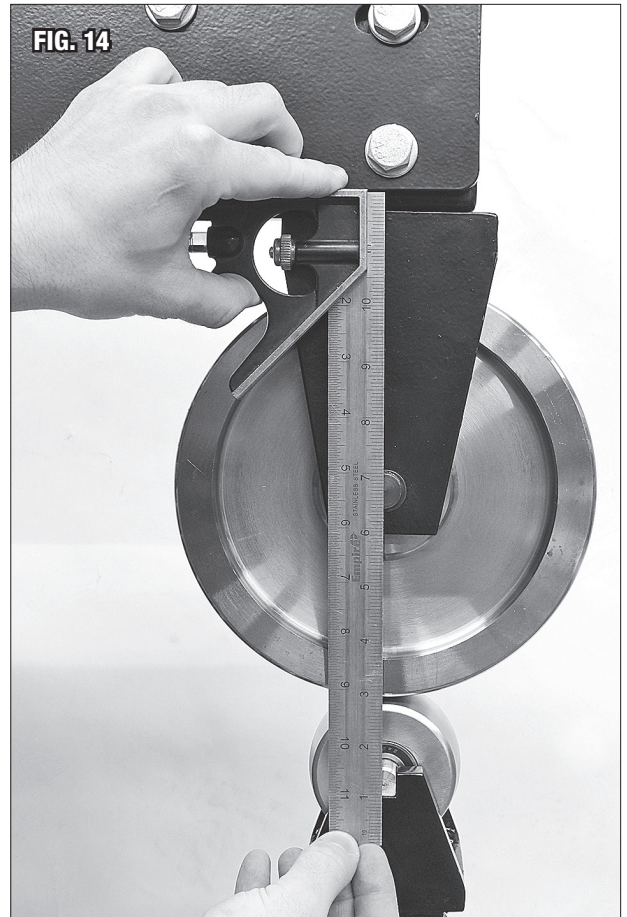

If more angle is needed on the Anvil, a strip of metal can be placed in the bottom of the Anvil Yoke slot (**FIG 17**) to shim the Anvil Axle up or down (**FIG 18**).

NOTE: some professional wheelers also utilize this method to purposely tilt an Anvil, using an edge to set a body line in a panel.

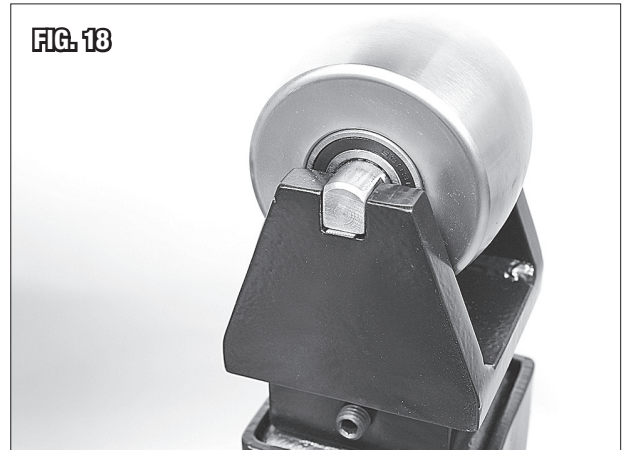
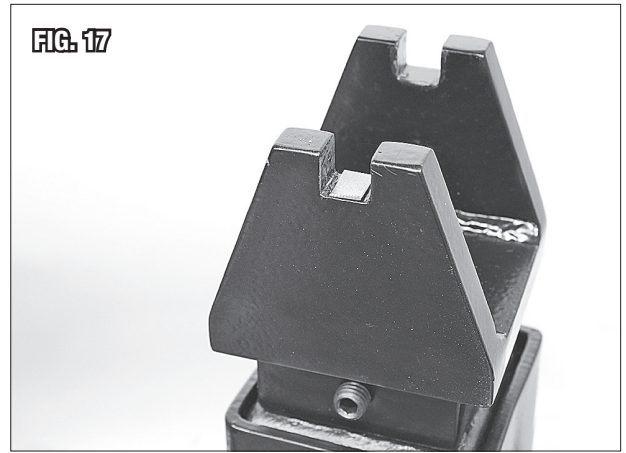

LARGE FRAME ENGLISH WHEEL USAGE

ANVIL SELECTION

- Each anvil has a different profile intended for creating a variety of contours in metal sheet. Choose the anvil with the profile that most closely matches the panel curvature to be achieved.
- The included Anvil set is comprised of 3" [76mm], 4" [102mm], 5" [127mm], 6" [152mm], 8" [203mm] radiused Anvils [K, L, M & N].
- Illustrated are the included Anvil Radii and the contours they can be expected to product (FIG 19).

FIG. 19

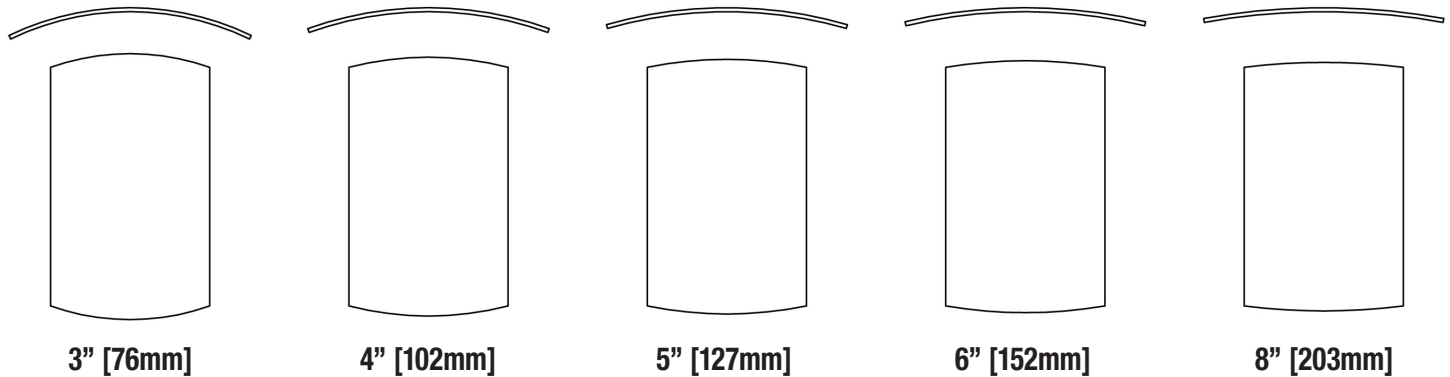

PANEL FORMING

English Wheeling is an age-old metal-working skill that many metal workers consider an art. Some amazing forms can be created in piece of metal when in the hands of an experienced wheeler. Keep in mind that there are differing methods of operation which vary among professional wheelers. None are absolutely fixed in stone as the "correct" way and none are wrong. It is simply a matter of choosing which method you find most comfortable as it is the results that matter most. The best method for learning is to obtain several metal-working books and videos containing material on English Wheeling by different well-known metal workers then determine which methods appeal most to you.

The #1 most important rule in becoming an expert in the time-honored art of English Wheeling is Practice, Practice, Practice. As with any professional metal working equipment, The English Wheel requires a learning curve to be able to achieve desired results that once achieved, prove to be highly satisfying.

The following are several basic elements crucial to English Wheeling:

- Obtain a stack of 8" x 10", 20-gauge aluminum and steel panels to use as practice pieces.
- Leave a gap equal to the thickness of the workpiece between the Wheel and Anvil. Place a practice piece of aluminum between them, then raise the Jackscrew until the anvil just contacts the metal and the metal contacts the Wheel, allowing easy rolling between the Anvil and Wheel (FIG 20).

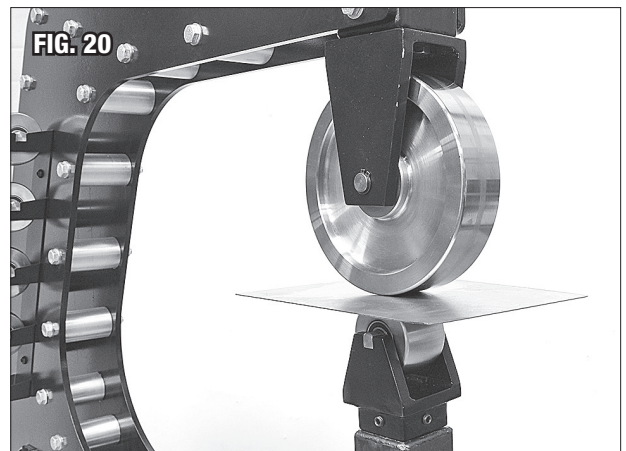

⚠ NOTICE

DO NOT overtighten the Jackscrew which would press the Anvil against the Wheel! Overtightening will quickly crease and harden the metal, create unnecessary effort, and will damage the surface of the Anvil. When forming a panel, only minimal pressure is required to hold the metal in place.

- Keep in mind that the metal forming is done by passing the metal over the anvil while pulling it down and shaping it. The Wheel functions as a guide.
- It is normal to constantly adjust the anvil tension as you work. The goal is to have it “not too tight yet not too loose.”
- Grasp the edges of the metal and continue to exert a gentle but firm downward force while rolling it. With repeated rolling, a curvature will begin to appear in the metal (**FIG 21**).
- Track the wheel close between runs. The lines should fully overlap in the desired forming area leaving no gaps (**FIG 22 LEFT SIDE**). Too much space between runs or too much pressure will result in a poorly formed panel (**FIG 22 RIGHT SIDE**). **NOTE:** For illustrative purposes the patterns shown in (**FIG 22**) have been exaggerated. In practice they pattern should be much tighter to effectively form a panel.
- Try not to repeatedly pass over the same point in the metal, which can work-harden it, but keep it moving in a tightly spaced, sweeping “W” or “X” pattern over the Anvil for best results. Note that the “W” pattern will produce a curve in one direction only while the “X” will produce a compound curve or “bowl” effect.
- Practicing these techniques will have you well on the way to becoming an expert English Wheeler! Continue practicing and you will be proud to have mastered a nearly forgotten metalworking skill that few in the world possess!

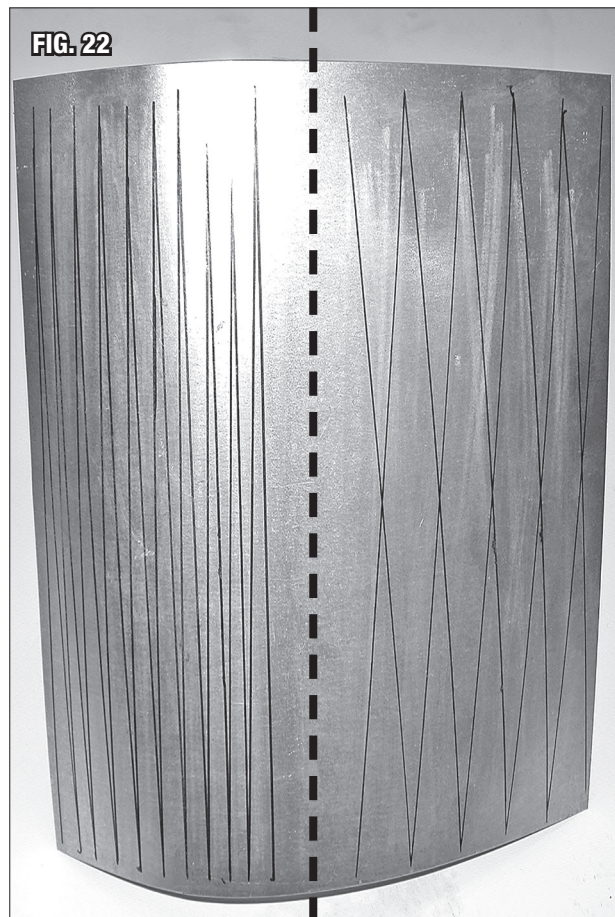
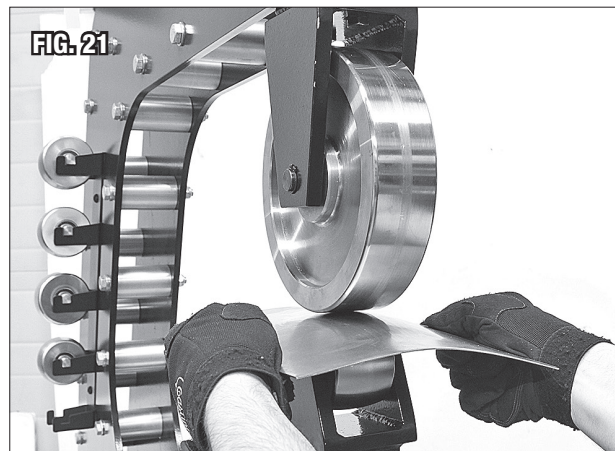

LONG PANELS

- When forming long panels, it may be optimal to change the direction you are wheeling. This is simple with the Large Frame English Wheel as it is easily indexed 90° so that the centerlines of the Wheel and Anvil are perpendicular to the axis of the Frame (**FIG 23**).
- Loosen the Anvil Tube set screws, Anvil Yoke set screws, and fully lower the Jackscrew.

⚠ WARNING PINCH AND CRUSH HAZARD!

The Wheel weighs over 22 lbs. [10 kg]! Use extreme care when handling. It is strongly recommended to have the help of an assistant available while removing or installing the Wheel.

- Remove the Wheel from the Wheel Yoke by utilizing snap ring pliers to remove one of the Wheel Axle snap rings (**FIG 24**). Slide the Axle out while holding up the wheel. The two spacers will also fall free as the Axle is removed. Set the Wheel, Axle, snap ring, and spacers aside.

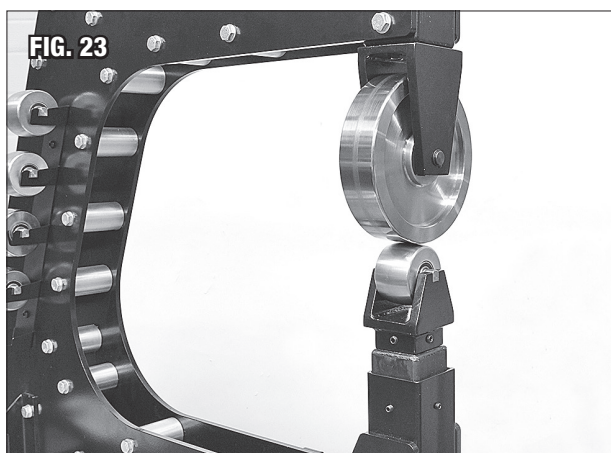

- Remove the two Wheel Yoke Mounting Screws. Note the other set of holes in the Wheel Yoke Mount Tube (**FIG 25**). The Wheel Yoke can now be indexed 90° and remounted. When tightening the screws visually square up the Wheel Yoke with the Wheel Yoke Tube and Frame (**FIG 26**).
- Carefully reinstall the Wheel and Axle with a spacer at both sides. The easiest way to accomplish this is:
 - Insert the Axle and place one of the spacers over it (**FIG 27**).
 - Carefully, as not to knock the spacer off, maneuver the Wheel into position and push the Axle through the two bearings (**FIG 28**).
 - Make sure the Axle is not protruding from the second bearing so that the spacer can still be installed.
 - Insert the spacer and push it all the way in (**FIG 29**). Now, with a small screwdriver, draw it into alignment (**FIG 30**) and push the Axle through completely.
 - Reinstall the snap ring.

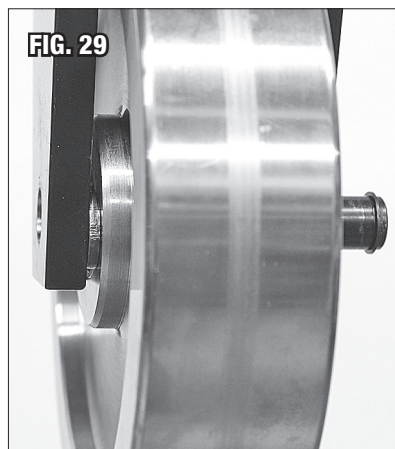
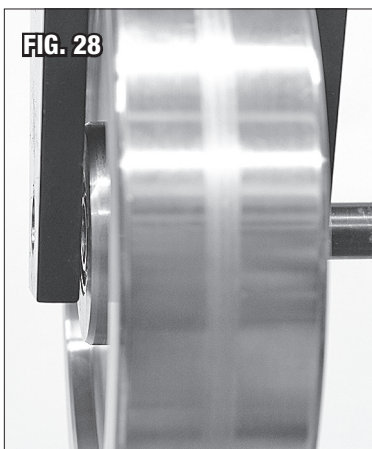
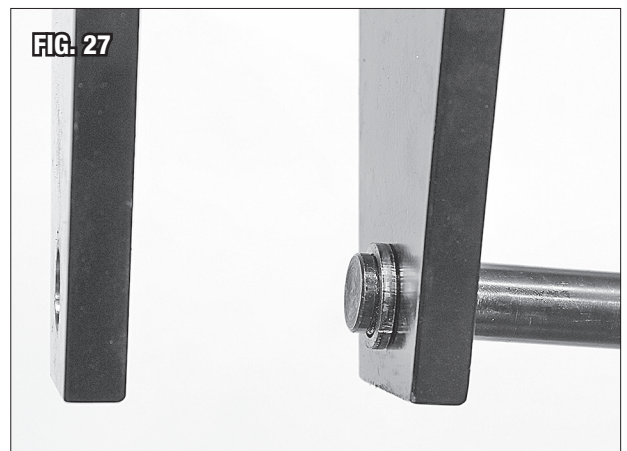
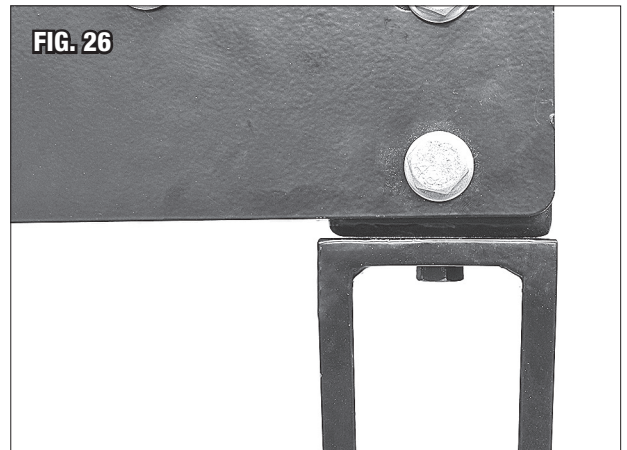

- Loosen the Anvil Yoke screws and rotate 90°. Check the alignment of Anvil to the Anvil Tube with a straight edge (**FIG 31**). If necessary, loosen the Anvil Yoke set screws and rotate into alignment.
- Raise the Anvil by turning the Jackscrew until it just touches the Wheel.
- As described previously, lay the straight edge at a diagonal across the Wheel and the Anvil (**FIG 15**) in both directions (**FIG 16**).
- The straight edge, ideally, should lay flush with both Wheel and Anvil faces. However, a 1/8" [3mm] gap will not affect wheeling. If adjustment is necessary:
 - Turn the Anvil Tube set screws in or out from opposite directions as needed to move the Anvil and Wheel into alignment.
 - With the alignment verified, the Anvil Tube set screws can be lightly tightened.

⚠ NOTICE

DO NOT over tighten the Anvil Tube Screws as the Anvil Tube needs to be able to move up and down smoothly. If more angle is needed on the Anvil, a strip of metal can be placed in the bottom of the Anvil Yoke slot (FIG 17) to shim the Anvil Axle up or down (FIG 18). NOTE: some professional wheelers also utilize this method to purposely tilt an Anvil, using an edge to set a body line in a panel.

MAINTENANCE

- Clean dirt and debris from Wheel and Anvil surfaces.
- Check tightness of all hardware.
- Check operation of Jackscrew for binding. Lubricate threads periodically with medium bodied chassis grease.
- When storing the English Wheel for an extended period of time, it is recommended to coat the wheel and anvils with a corrosion inhibitor to prevent surface rust. Mineral oil and motor oil are two good options for this task.



ADDITIONAL ITEMS

R&D MUST-HAVE ACCESSORIES



#20637
English Wheel Forming Band



#51088
Eastwood Shrinker/Stretcher Combo Set



#21111
Bead Roller Drive System



#20267
Eastwood Bead Roller
Metal Fabrication Forming Dies



#13475
Eastwood Electric Metal Cutting Shears

Visit eastwood.com for complete info and pricing.

If you have any questions about the use of this product, please contact

The Eastwood Technical Assistance Service Department: 800.343.9353 >> email: tech@eastwood.com

PDF version of this manual is available at eastwood.com

The Eastwood Company 263 Shoemaker Road, Pottstown, PA 19464, USA 800.343.9353 eastwood.com

© Copyright 2022 Eastwood Automotive Group LLC 11/22 Instruction item #64646Q Rev 2