



OPERATOR'S MANUAL

Metal Working



3-IN-1 COMBINATION SHEAR, BRAKE, ROLL MODEL: SBR-5220

Baileigh Industrial Holdings LLC
P.O. Box 531
Manitowoc, WI 54221-0531
Phone: 920.684.4990
Fax: 920.684.3944
sales@baileigh.com

REPRODUCTION OF THIS MANUAL IN ANY FORM WITHOUT WRITTEN APPROVAL OF BAILEIGH INDUSTRIAL HOLDINGS LLC IS PROHIBITED. Baileigh Industrial Holdings LLC, Inc. does not assume and hereby disclaims any liability for any damage or loss caused by an omission or error in this Operator's Manual, resulting from accident, negligence, or other occurrence.

Rev. 04/2021

© 2021 Baileigh Industrial Holdings LLC



Table of Contents

THANK YOU & WARRANTY	1
INTRODUCTION.....	3
GENERAL NOTES.....	3
SAFETY INSTRUCTIONS	4
SAFETY PRECAUTIONS	7
Dear Valued Customer:.....	7
TECHNICAL SPECIFICATIONS	9
TECHNICAL SUPPORT	9
UNPACKING AND CHECKING CONTENTS.....	10
TRANSPORTING AND LIFTING	12
INSTALLATION.....	13
Anchoring the Machine.....	14
OVERALL DIMENSIONS.....	15
GETTING TO KNOW YOUR MACHINE	16
ASSEMBLY AND SET UP	17
SHEAR OVERVIEW	18
Shearing Tips	18
SHEARING SHEET METAL	19
SHEAR BLADE ADJUSTMENTS.....	21
Adjustment Results.....	21
HOLD DOWN ADJUSTMENT	22
How to Adjust the Hold down.....	22
REMOVAL OF BRAKE BLADES FOR CLEANING AND SETUP	23
Installing the Brake Blades	23
BRAKE OVERVIEW.....	24
Bending Allowance	24
BENDING SHEET METAL.....	25
Basic Bend Operation.....	25
SLIP ROLL OVERVIEW.....	27
OPERATING THE SLIP ROLL.....	28
Determining Length of Material.....	28
Pre-Bending and Finish Rolling	28
Rolling Operation.....	29
Rolling Round Shapes.....	31
BENDING ALLOWANCE	32
UNDERSTANDING SPRINGBACK	32
MATERIAL SELECTION.....	32
LUBRICATION AND MAINTENANCE	33
SLIP ROLL MAINTENANCE	34
BRAKE ALIGNMENT.....	35
REPLACING THE SHEAR BLADE	36
Replace Blades	36
PARTS IDENTIFICATION DRAWING - A.....	37



PARTS IDENTIFICATION DRAWING - B.....	38
PARTS IDENTIFICATION DRAWING - C.....	39
Parts List	40
TROUBLESHOOTING	43
Shear Operation	43
Brake Operation	43
Slip Roll Operation.....	43



THANK YOU & WARRANTY

Thank you for your purchase of a machine from Baileigh Industrial Holdings LLC. We hope that you find it productive and useful to you for a long time to come.

Inspection & Acceptance. Buyer shall inspect all Goods within ten (10) days after receipt thereof. Buyer's payment shall constitute final acceptance of the Goods and shall act as a waiver of the Buyer's rights to inspect or reject the goods unless otherwise agreed. If Buyer rejects any merchandise, Buyer must first obtain a Returned Goods Authorization ("RGA") number before returning any goods to Seller. Goods returned without an RGA will be refused. Seller will not be responsible for any freight costs, damages to goods, or any other costs or liabilities pertaining to goods returned without a RGA. Seller shall have the right to substitute a conforming tender. Buyer will be responsible for all freight costs to and from Buyer and repackaging costs, if any, if Buyer refuses to accept shipment. If Goods are returned in unsalable condition, Buyer shall be responsible for full value of the Goods. Buyer may not return any special-order Goods. Any Goods returned hereunder shall be subject to a restocking fee equal to 30% of the invoice price.

Specifications. Seller may, at its option, make changes in the designs, specifications or components of the Goods to improve the safety of such Goods, or if in Seller's judgment, such changes will be beneficial to their operation or use. Buyer may not make any changes in the specifications for the Goods unless Seller approves of such changes in writing, in which event Seller may impose additional charges to implement such changes.

Limited Warranty. Seller warrants to the original end-user that the Goods manufactured or provided by Seller under this Agreement shall be free of defects in material or workmanship for a period of twelve (12) months from the date of purchase, provided that the Goods are installed, used, and maintained in accordance with any instruction manual or technical guidelines provided by the Seller or supplied with the Goods, if applicable. The original end-user must give written notice to Seller of any suspected defect in the Goods prior to the expiration of the warranty period. The original end-user must also obtain a RGA from Seller prior to returning any Goods to Seller for warranty service under this paragraph. Seller will not accept any responsibility for Goods returned without a RGA. The original end-user shall be responsible for all costs and expenses associated with returning the Goods to Seller for warranty service. In the event of a defect, Seller, at its sole option, shall repair or replace the defective Goods or refund to the original end-user the purchase price for such defective Goods. Goods are not eligible for replacement or return after a period of 10 days from date of receipt. The foregoing warranty is Seller's sole obligation, and the original end-user's exclusive remedy, with regard to any defective Goods. This limited warranty does not apply to: (a) die sets, tooling, and saw blades; (b) periodic or routine maintenance and setup, (c) repair or replacement of the Goods due to normal wear and tear, (d) defects or damage to the Goods resulting from misuse, abuse, neglect, or accidents, (e) defects or damage to the Goods resulting from improper or unauthorized alterations, modifications, or changes; and (f) any Goods that has not been installed and/or maintained in accordance with the instruction manual or technical guidelines provided by Seller.

EXCLUSION OF OTHER WARRANTIES. THE FOREGOING LIMITED WARRANTY IS IN LIEU OF ALL OTHER WARRANTIES, EXPRESS OR IMPLIED. ANY AND ALL OTHER EXPRESS, STATUTORY OR IMPLIED WARRANTIES, INCLUDING BUT NOT LIMITED TO, ANY WARRANTY OF MERCHANTABILITY OR FITNESS FOR ANY PARTICULAR PURPOSE ARE EXPRESSLY DISCLAIMED. NO WARRANTY IS MADE WHICH EXTENDS BEYOND THAT WHICH IS EXPRESSLY CONTAINED HEREIN.

Limitation of Liability. IN NO EVENT SHALL SELLER BE LIABLE TO BUYER OR ANY OTHER PARTY FOR ANY INCIDENTAL, CONSEQUENTIAL OR SPECIAL DAMAGES (INCLUDING, WITHOUT LIMITATION, LOST PROFITS OR DOWN TIME) ARISING FROM OR IN MANNER CONNECTED WITH THE GOODS, ANY BREACH BY SELLER OR ITS AGENTS OF THIS AGREEMENT, OR ANY OTHER CAUSE WHATSOEVER, WHETHER BASED ON CONTRACT, TORT OR ANY OTHER THEORY OF LIABILITY. BUYER'S REMEDY WITH RESPECT TO ANY CLAIM ARISING UNDER THIS AGREEMENT IS STRICTLY LIMITED TO NO MORE THAN THE AMOUNT PAID BY THE BUYER FOR THE GOODS.



Force Majeure. Seller shall not be responsible for any delay in the delivery of, or failure to deliver, Goods due to causes beyond Seller's reasonable control including, without limitation, acts of God, acts of war or terrorism, enemy actions, hostilities, strikes, labor difficulties, embargoes, non-delivery or late delivery of materials, parts and equipment or transportation delays not caused by the fault of Seller, delays caused by civil authorities, governmental regulations or orders, fire, lightening, natural disasters or any other cause beyond Seller's reasonable control. In the event of any such delay, performance will be postponed by such length of time as may be reasonably necessary to compensate for the delay.

Installation. If Buyer purchases any Goods that require installation, Buyer shall, at its expense, make all arrangements and connections necessary to install and operate the Goods. Buyer shall install the Goods in accordance with any Seller instructions and shall indemnify Seller against any and all damages, demands, suits, causes of action, claims and expenses (including actual attorneys' fees and costs) arising directly or indirectly out of Buyer's failure to properly install the Goods.

Work By Others; Safety Devices. Unless agreed to in writing by Seller, Seller has no responsibility for labor or work performed by Buyer or others, of any nature, relating to design, manufacture, fabrication, use, installation or provision of Goods. Buyer is solely responsible for furnishing and requiring its employees and customers to use all safety devices, guards and safe operating procedures required by law and/or as set forth in manuals and instruction sheets furnished by Seller. Buyer is responsible for consulting all operator manuals, ANSI or comparable safety standards, OSHA regulations and other sources of safety standards and regulations applicable to the use and operation of the Goods.

Remedies. Each of the rights and remedies of Seller under this Agreement is cumulative and in addition to any other or further remedies provided under this Agreement or at law or equity.

Attorney's Fees. In the event legal action is necessary to recover monies due from Buyer or to enforce any provision of this Agreement, Buyer shall be liable to Seller for all costs and expenses associated therewith, including Seller's actual attorney fees and costs.

Governing Law/Venue. This Agreement shall be construed and governed under the laws of the State of Wisconsin, without application of conflict of law principles. Each party agrees that all actions or proceedings arising out of or in connection with this Agreement shall be commenced, tried, and litigated only in the state courts sitting in Manitowoc County, Wisconsin or the U.S. Federal Court for the Eastern District of Wisconsin. Each party waives any right it may have to assert the doctrine of "forum non conveniens" or to object to venue to the extent that any proceeding is brought in accordance with this section. Each party consents to and waives any objection to the exercise of personal jurisdiction over it by courts described in this section. Each party waives to the fullest extent permitted by applicable law the right to a trial by jury.

Summary of Return Policy.

- 10 Day acceptance period from date of delivery. Damage claims and order discrepancies will not be accepted after this time.
- You must obtain a Baileigh issued RGA number PRIOR to returning any materials.
- Returned materials must be received at Baileigh in new condition and in original packaging.
- Altered items are not eligible for return.
- Buyer is responsible for all shipping charges.
- A 30% re-stocking fee applies to all returns.

Baileigh Industrial Holdings LLC makes every effort to ensure that our posted specifications, images, pricing and product availability are as correct and timely as possible. We apologize for any discrepancies that may occur. Baileigh Industrial Holdings LLC reserves the right to make any and all changes deemed necessary in the course of business including but not limited to pricing, product specifications, quantities, and product availability.

For Customer Service & Technical Support:

Please contact one of our knowledgeable Sales and Service team members at:
(920) 684-4990 or e-mail us at sales@baileigh.com



INTRODUCTION

The quality and reliability of the components assembled on a Baileigh Industrial Holdings LLC machine guarantee near perfect functioning, free from problems, even under the most demanding working conditions. However, if a situation arises, refer to the manual first. If a solution cannot be found, contact the distributor where you purchased our product. Make sure you have the serial number and production year of the machine (stamped on the nameplate). For replacement parts refer to the assembly numbers on the parts list drawings.

Our technical staff will do their best to help you get your machine back in working order.

In this manual you will find: (when applicable)

- Safety procedures
- Correct installation guidelines
- Description of the functional parts of the machine
- Capacity charts
- Setup and start-up instructions
- Machine operation
- Scheduled maintenance
- Parts lists

GENERAL NOTES

After receiving your equipment remove the protective container. Do a complete visual inspection, and if damage is noted, **photograph it for insurance claims** and contact your carrier at once, requesting inspection. Also contact Baileigh Industrial Holdings LLC and inform them of the unexpected occurrence. Temporarily suspend installation.

Take necessary precautions while loading / unloading or moving the machine to avoid any injuries.

Your machine is designed and manufactured to work smoothly and efficiently. Following proper maintenance instructions will help ensure this. Try and use original spare parts, whenever possible, and most importantly; **DO NOT** overload the machine or make any modifications.



Note: This symbol refers to useful information throughout the manual.



IMPORTANT

PLEASE READ THIS OPERATORS MANUAL CAREFULLY

It contains important safety information, instructions, and necessary operating procedures. The continual observance of these procedures will help increase your production and extend the life of the equipment.

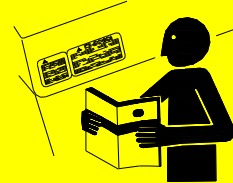

SAFETY INSTRUCTIONS

LEARN TO RECOGNIZE SAFETY INFORMATION

This is the safety alert symbol. When you see this symbol on your machine or in this manual, **BE ALERT TO THE POTENTIAL FOR PERSONAL INJURY!**



Follow recommended precautions and safe operating practices.

UNDERSTAND SIGNAL WORDS

A signal word – **DANGER**, **WARNING**, or **CAUTION** – is used with the safety alert symbol. **NOTICE**, which is not related to personal injury, is used without a symbol.

DANGER: Indicates a hazardous situation which, if not avoided, will result in death or serious injury.

WARNING: Indicates a hazardous situation which, if not avoided, could result in death or serious injury.

CAUTION: Indicates a hazardous situation which, if not avoided, could result in minor or moderate injury.

NOTICE: Indicates a situation which, if not avoided, could result in property damage.

DANGER

WARNING

CAUTION

NOTICE



SAVE THESE INSTRUCTIONS.
Refer to them often and use them to instruct others.



PROTECT EYES

Wear safety glasses or suitable eye protection when working on or around machinery.

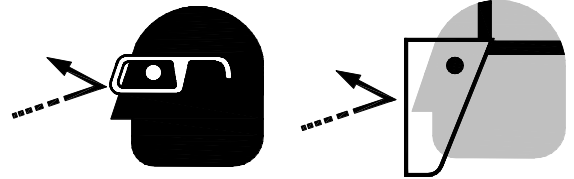

PROTECT AGAINST NOISE

Prolonged exposure to loud noise can cause impairment or loss of hearing. Wear suitable hearing protective devices such as ear muffs or earplugs to protect against objectionable or uncomfortable loud noises.

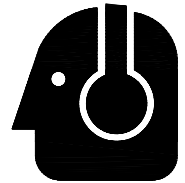

BEWARE OF CRUSH HAZARD

Closing upper beam and brake bed will result in loss of fingers or limbs if placed in machine. **NEVER** place your hand or any part of your body in this machine.



BEWARE OF CRUSH HAZARD

NEVER place your hands, fingers, or any part of your body in the die area of this machine.

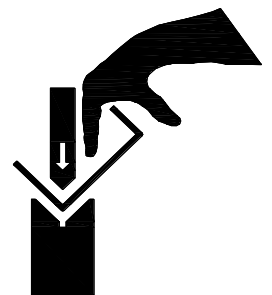
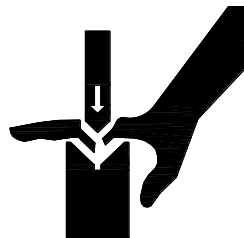

KEEP CLEAR OF MOVING OBJECTS

Always be aware of the position of the clamp handle and the counterweight. They are heavy and can swing back suddenly causing serious body or head injuries.

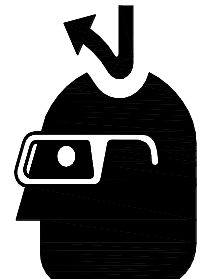



BEWARE OF PINCH POINTS

Keep hands and fingers away from the rolls when the machine is in operation.

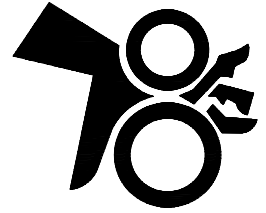

BEWARE OF SHEAR, PINCH, AND CRUSH HAZARD

NEVER place your hands, fingers, or any part of your body in the die area of this machine. Keep hands and fingers away from the shear blade and the punching and notching dies when the machine is in operation.

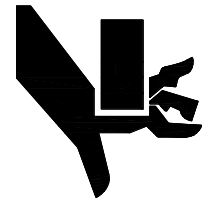

BEWARE OF SHEAR HAZARD

Keep hands and fingers clear from under the blade.
NEVER place your hand or any part of your body in this machine.

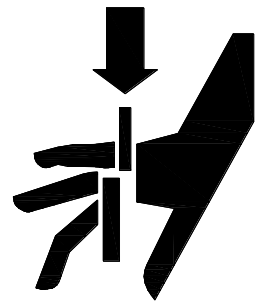

CALIFORNIA PROPOSITION 65

WARNING: Cancer and Reproductive Harm.
www.P65Warnings.ca.gov



WARNING: Before operating the Baileigh Shear, Brake, Roll make sure it is firmly bolted to a table, bench, or the floor. If it tips over on you, it could cause severe injury or death.



WARNING:

The bending brake poses a pinching hazard.
The shear blade poses an amputation hazard.
Make sure no body part or clothing is near the specific hazard. Failure to follow this warning could result in severed or crushed fingers.



SAFETY PRECAUTIONS



Metal working can be dangerous if safe and proper operating procedures are not followed. As with all machinery, there are certain hazards involved with the operation of the product. Using the machine with respect and caution will considerably lessen the possibility of personal injury. However, if normal safety precautions are overlooked or ignored, personal injury to the operator may result.

Safety equipment such as guards, hold-downs, safety glasses, dust masks and hearing protection can reduce your potential for injury. But even the best guard will not make up for poor judgment, carelessness or inattention. **Always use common sense** and exercise **caution** in the workshop. If a procedure feels dangerous, don't try it.

REMEMBER: Your personal safety is your responsibility.



WARNING: FAILURE TO FOLLOW THESE RULES MAY RESULT IN SERIOUS PERSONAL INJURY

Dear Valued Customer:

- All Baileigh machines should be used only for their intended use.
- Baileigh does not recommend or endorse making any modifications or alterations to a Baileigh machine. Modifications or alterations to a machine may pose a substantial risk of injury to the operator or others and may do substantial damage to the machine.
- Any modifications or alterations to a Baileigh machine will invalidate the machine's warranty.

PLEASE ENJOY YOUR BAILEIGH MACHINE!PLEASE ENJOY IT SAFELY!

1. **FOR YOUR OWN SAFETY, READ INSTRUCTION MANUAL BEFORE OPERATING THE MACHINE.** Learn the machine's application and limitations as well as the specific hazards.
2. **Only trained and qualified personnel can operate this machine.**
3. **Make sure guards are in place and in proper working order before operating machinery.**
4. **Remove any adjusting tools.** Before operating the machine, make sure any adjusting tools have been removed.
5. **Keep work area clean.** Cluttered areas invite injuries.
6. **Overloading machine.** By overloading the machine, you may cause injury from flying parts. **DO NOT** exceed the specified machine capacities.
7. **Dressing material edges.** Always chamfer and deburr all sharp edges.



8. **Do not force tool.** Your machine will do a better and safer job if used as intended. **DO NOT** use inappropriate attachments in an attempt to exceed the machine's rated capacity.
9. **Use the right tool for the job. DO NOT** attempt to force a small tool or attachment to do the work of a large industrial tool. **DO NOT** use a tool for a purpose for which it was not intended.
10. **Dress appropriately. DO NOT** wear loose fitting clothing or jewelry as they can be caught in moving machine parts. Protective clothing and steel toe shoes are recommended when using machinery. Wear a restrictive hair covering to contain long hair.
11. **Use eye protection.** Always wear ISO approved protective eye wear when operating machinery. Wear a full-face shield if you are producing metal filings. Eye wear shall be impact resistant, protective safety glasses with side shields which comply with ANSI Z87.1 specification. Use of eye wear which does not comply with ANSI Z87.1 specification could result in severe injury from breakage of eye protection.
12. **Do not overreach.** Maintain proper footing and balance at all times. **DO NOT** reach over or across a running machine.
13. **Stay alert.** Watch what you are doing and use common sense. **DO NOT** operate any tool or machine when you are tired.
14. **Check for damaged parts.** Before using any tool or machine, carefully check any part that appears damaged. Check for alignment and binding of moving parts that may affect proper machine operation.
15. **Observe work area conditions. DO NOT** use machines or power tools in damp or wet locations. Do not expose to rain. Keep work area well lighted.
16. **Blade adjustments and maintenance.** Always keep blades sharp and properly adjusted for optimum performance.
17. **Keep children away.** Children must never be allowed in the work area. **DO NOT** let them handle machines, tools, or extension cords.
18. Keep visitors a safe distance from the work area.
19. **Store idle equipment.** When not in use, tools must be stored in a dry location to inhibit rust. Always lock up tools and keep them out of reach of children.
20. **DO NOT operate machine if under the influence of alcohol or drugs.** Read warning labels on prescriptions. If there is any doubt, **DO NOT** operate the machine.



TECHNICAL SPECIFICATIONS

Bed Width	52" (1321mm)
Shear Capacity	20ga. (.912mm) mild steel*
Bending Capacity	20ga. (.912mm) mild steel*
Rolling Capacity	20ga. (.912mm) mild steel*
Maximum Bend Angle	90°
Slip Roll Solid Rod Sizes	.187" (4.76mm) diameter, .250" (6.35mm) diameter, .312" (7.92mm) diameter
Minimum Roll Diameter	2" (51mm)
Box Depth	4" (101.6mm)
Frame and Base	Cast Iron
Brake	Ground Steel w/Hardened Edge
Shear Table	Precision Ground Cast Iron
Shear Blades	Hardened Steel (Can be turned four times)
Shear Hold-Down Clamp	Spring-Loaded Cast Iron
Diameter of Rolls	1.968" (50mm)
Power Requirements	Manual
Shipping Dimensions (L x W x H)	67" x 30" x 46" (1702 x 762 x 1168mm)
Shipping Weight	1200 lbs. (545 kg)
Based on a material tensile strength of *60000 PSI – mild steel	

TECHNICAL SUPPORT

Our technical support department can be reached at 920.684.4990 and asking for the support desk for purchased machines. Tech Support handles questions on machine setup, schematics, warranty issues, and individual parts needs: (other than die sets and blades).

For specific application needs or future machine purchases contact the Sales Department at: sales@baileigh.com, Phone: 920.684.4990, or Fax: 920.684.3944.



Note: *The photos and illustrations used in this manual are representative only and may not depict the actual color, labeling or accessories and may be intended to illustrate technique only.*



Note: *The specifications and dimensions presented here are subject to change without prior notice due to improvements of our products.*



UNPACKING AND CHECKING CONTENTS

Your Baileigh machine is shipped complete. Separate all parts from the packing material and check each item carefully. Make certain all items are accounted for before discarding any packing material.

⚠ WARNING: SUFFOCATION HAZARD! Immediately discard any plastic bags and packing materials to eliminate choking and suffocation hazards to children and animals.
If any parts are missing, **DO NOT** place the machine into service until the missing parts are obtained and installed correctly.

Cleaning

⚠ WARNING: DO NOT USE gasoline or other petroleum products to clean the machine. They have low flash points and can explode or cause fire.

⚠ CAUTION: When using cleaning solvents work in a well-ventilated area. Many cleaning solvents are toxic if inhaled.

Your machine may be shipped with a rustproof waxy coating and/or grease on the exposed unpainted metal surfaces. Fully and completely remove this protective coating using a degreaser or solvent cleaner. Moving items will need to be moved along their travel path to allow for cleaning the entire surface. For a more thorough cleaning, some parts will occasionally have to be removed. **DO NOT USE** acetone or brake cleaner as they may damage painted surfaces.

Follow manufacturer's label instructions when using any type of cleaning product. After cleaning, wipe unpainted metal surfaces with a light coating of quality oil or grease for protection.



Important: This waxy coating is **NOT** a lubricant and will cause the machine to stick and lose performance as the coating continues to dry.





Combination Shear, Brake, Roll



Rear Stop



Handlebars



Rear Stop Rods



Covers



TRANSPORTING AND LIFTING

NOTICE: *Lifting and carrying operations should be carried out by skilled workers, such as a truck operator, crane operator, etc. If a crane is used to lift the machine, attach the lifting chain carefully, making sure the machine is well balanced.*

Follow these guidelines when lifting with truck or trolley:

- The lift truck must be able to lift at least 1.5 – 2 times the machines gross weight.
- Make sure the machine is balanced. While transporting, avoid rough or jerky motion, and maintain a safe clearance zone around the transport area.
- Use a forklift with sufficient lifting capacity and forks that are long enough to reach the complete width of the machine.
- Remove the securing bolts that attach the machine to the pallet.
- Approaching the machine from the side, lift the machine on the frame taking care that there are no cables or pipes in the area of the forks.
- Move the machine to the required position and lower gently to the floor.
- Level the machine so that all the supporting feet are taking the weight of the machine and no rocking is taking place.

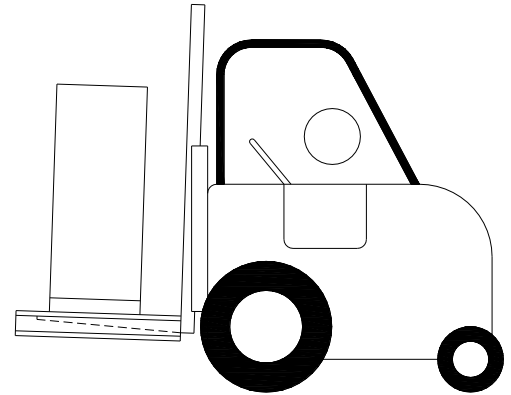

Follow these guidelines when lifting crane or hoist:

- Always lift and carry the machine with the lifting holes provided at the top of the machine.
- Use lift equipment such as straps, chains, capable of lifting 1.5 to 2 times the weight of the machine.
- Take proper precautions for handling and lifting.
- Check if the load is properly balanced by lifting it an inch or two.
- Lift the machine, avoiding sudden accelerations or quick changes of direction.
- Locate the machine where it is to be installed, then lower slowly until it touches the floor.





INSTALLATION



WARNING: It is absolutely imperative that this machine be anchored securely to the floor to prevent tipping.

If this machine is installed on a work bench or stand of any type, then the mounting to the bench or stand **AND** the stand must be anchored in such a way as to prevent tipping.

At full capacity, the leverage of both handles extending fully forward with each operator pulling downward **WILL** cause the machine to tip if not properly anchored.

IMPORTANT:

Consider the following when looking for a suitable location to place the machine:

- Overall weight of the machine.
- Weight of material being processed.
- Sizes of material to be processed through the machine.
- Space needed for auxiliary stands, work tables, or other machinery.
- Clearance from walls and other obstacles.
- Maintain an adequate working area around the machine for safety.
- Have the work area well illuminated with proper lighting.
- Keep the floor free of oil and make sure it is not slippery.
- Remove scrap and waste materials regularly, and make sure the work area is free from obstructing objects.
- If long lengths of material are to be fed into the machine, make sure that they will not extend into any aisles.
- **LEVELING:** The machine should be sited on a level, concrete floor. Provisions for securing it should be in position prior to placing the machine. The accuracy of any machine depends on the precise placement of it to the mounting surface.
- **FLOOR:** This tool distributes a large amount of weight over a small area. Make certain that the floor is capable of supporting the weight of the machine, work stock, and the operator. The floor should also be a level surface. If the unit wobbles or rocks once in place, be sure to eliminate by using shims.
- **WORKING CLEARANCES:** Take into consideration the size of the material to be processed. Make sure that you allow enough space for you to operate the machine freely. This shall include the full rotation of the handles at full extension.



Anchoring the Machine

- Once positioned, anchor the machine to the floor, as shown in the diagram. Use bolts and expansion plugs or sunken tie rods that connect through and are sized for the holes in the base of the stand.
- This machine requires a solid floor such as concrete at a minimum of 4" (102mm) thick. 6" (153mm) minimum is preferred.

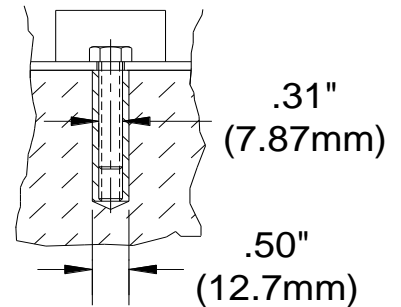

If you intend to mount the Baileigh machine on a workbench be aware of the following:

- Overall weight of the machine.
- Weight of material being processed.
- Make sure the workbench is properly reinforced to support the weight.
- The strongest mounting option is where the holes are drilled all the way through the workbench and the machine is secured with bolts, washers, and nuts.



OVERALL DIMENSIONS

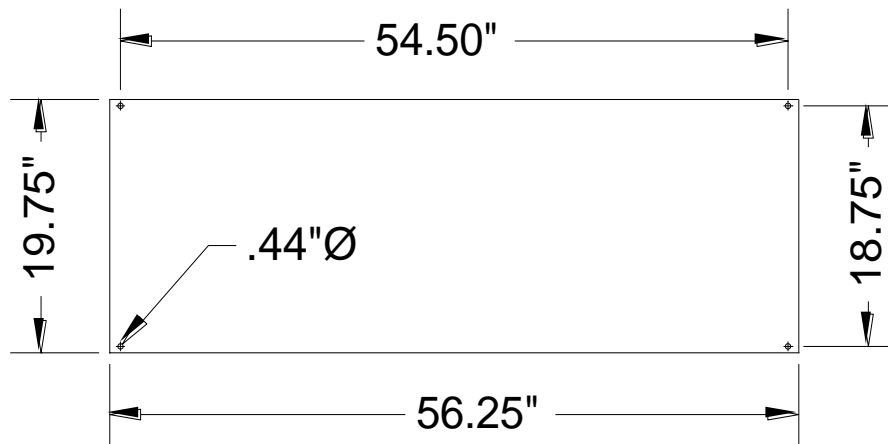
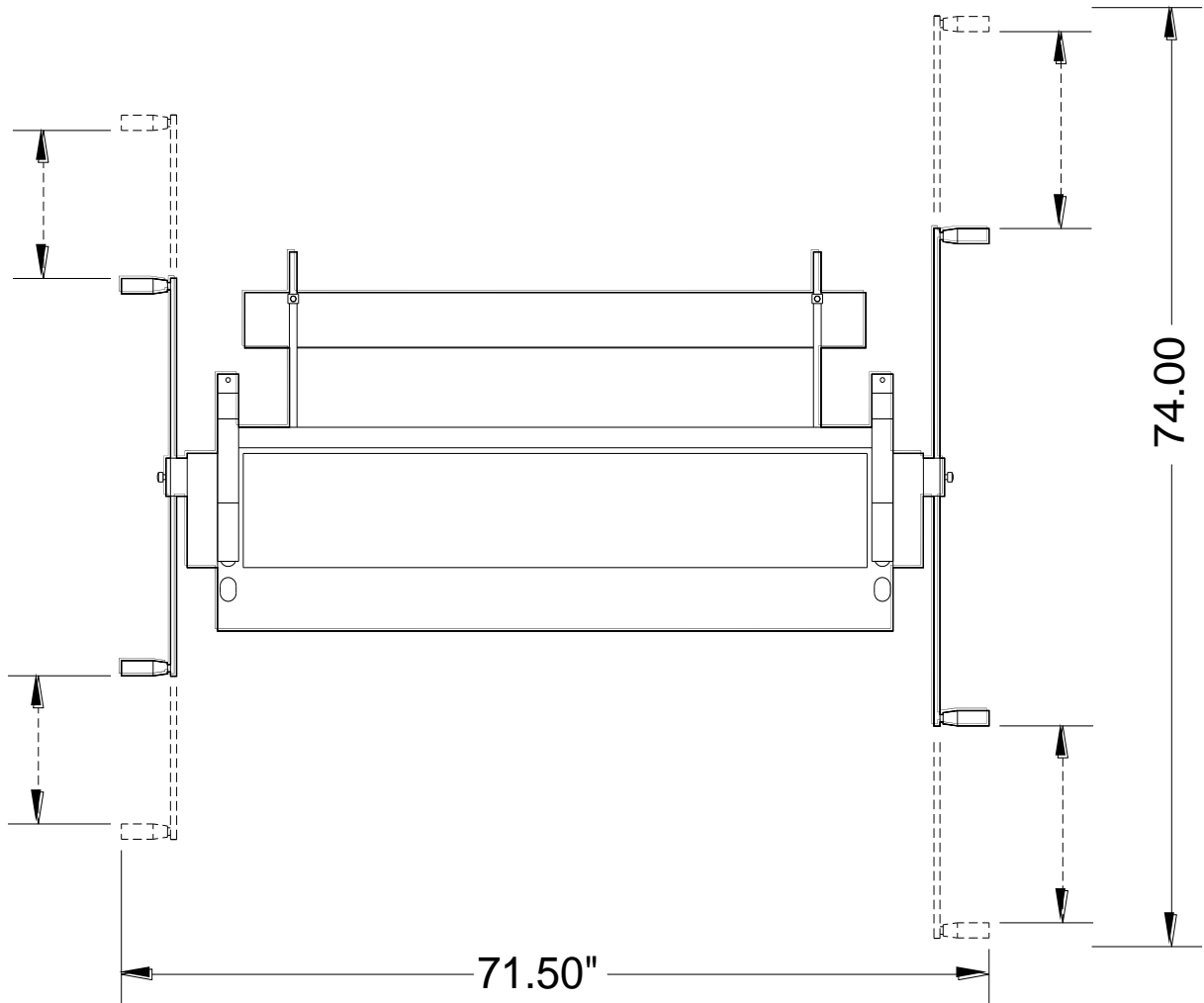

Mounting Holes



GETTING TO KNOW YOUR MACHINE

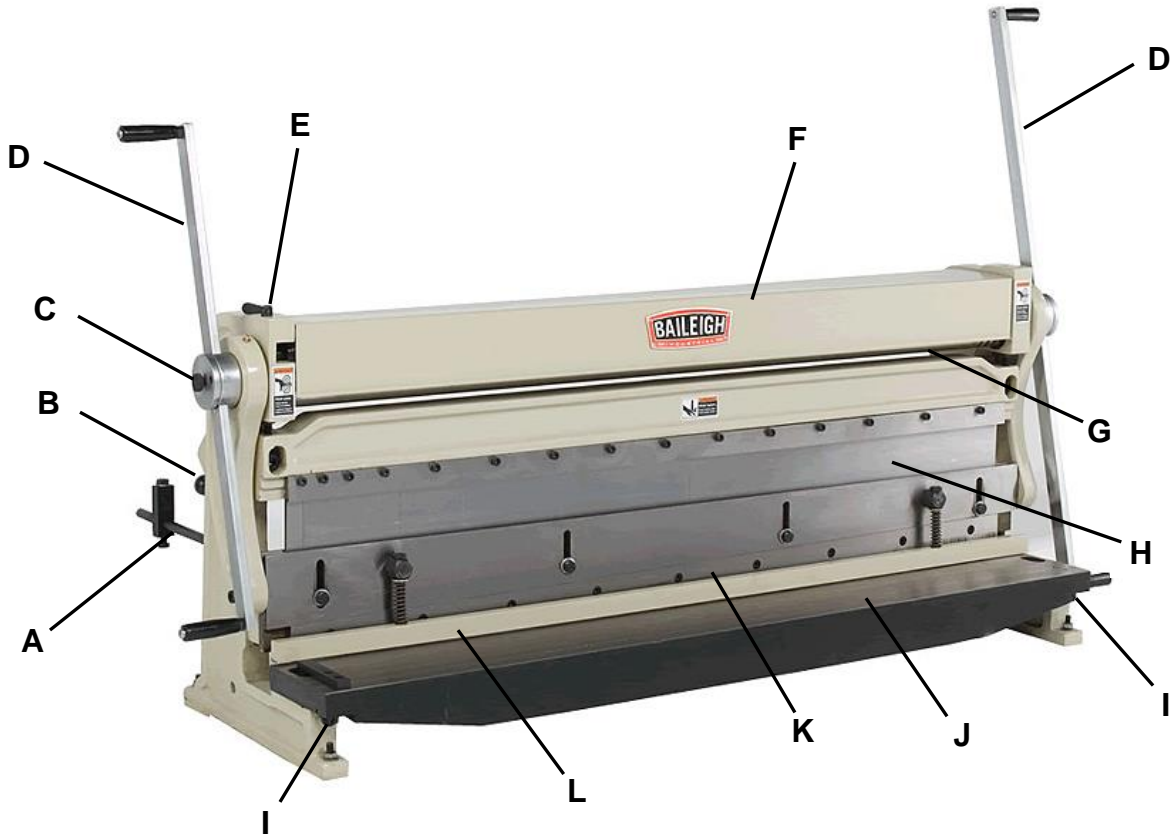

Item	Description	Function
A	Back Gauge	Controls material stop distance for brake and shear
B	Rear Roller Adjustment Knob	Clockwise to raise and counterclockwise to lower
C	Handlebar Adjustment Knob	Loosen knob and adjust handlebar position
D	Handlebars	Controls motion of the rolls, shear, and brake
E	Upper Roller Adjustment Knob	Clockwise to lower and counterclockwise to raise
F	Slip Roll Cover	Covers rolls when not being used
G	Slip Roll	Forming material
H	Brake Fingers	Presses down on the material to form the bend
I	Shear Adjustment Screws	Adjusting shear blade gap
J	Work Apron	Place material on this surface when shearing
K	Shear Blade	Cuts material
L	Spring Loaded Hold Down	Controls the hold down feed gap



ASSEMBLY AND SET UP

1. This machine comes with one long (39.5" [1003mm]) and one short (31.5" [800mm]) handlebars. It is the owners/operators choice as to which end of the machine the handlebars are installed into.
2. Remove the swivel handle (52) from the handlebar.
3. Loosen the thumb bolt, (11) enough to allow the handlebar to slide into the hub.
4. Extend the handlebar though the hub enough to allow the swivel handle to be installed.
5. Tighten the thumb bolt (11) to hold the handlebar in position.
6. Install and tighten the swivel handle (52) to prevent the handlebar from coming out of the hub and to provide the handle for pulling the machine during operation.

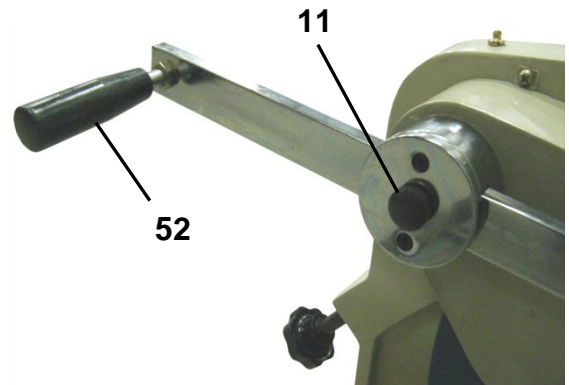

Note: Do not overtighten the thumb bolt. The handlebar is typically slide from the center position to full extension as the material increases toward full capacity.

7. Repeat this procedure at the other end of the machine with the other handlebar.
8. Thread the upper roll adjusting knobs into the tapped holes on the top of each side plate as shown.
9. Tighten the knobs until just snug.
10. Thread both back stop extension rods (#28) into the lower set of holes as shown. These holes are located on the outfeed side of the casting.

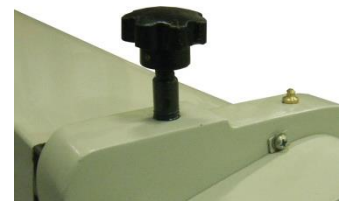

Note: With the back gauge (33) is on the top of the rods, the back gauge will be aligned for use with the brake. When the back gauge is below the rods the back gauge will be aligned for use with the shear.



11. Fasten both mounting collars (#29) to the back gauge (#33). The stand dies can now be positioned where needed on the long rods to locate the back gauge.

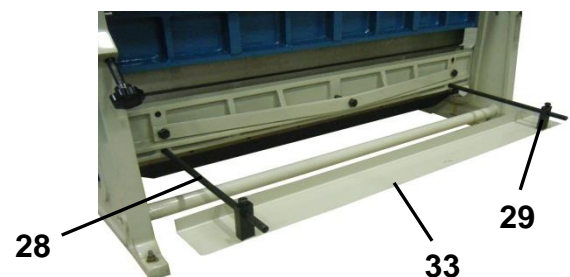



SHEAR OVERVIEW

The shear section has blades that can be reversed to provide a sharp edge as needed and are capable of shearing up to 20 gauge (0.912mm) mild steel sheet x 52" (1321mm) wide. An adjustable upper blade assembly passes by a fixed lower blade resulting in a precise shearing action. If necessary, the back gauge can be adjusted to accommodate repeat pieces.

Shearing Tips

- Keep the blade gap to the smallest distance possible.
- When shearing, the work should be squared against a guide.
- The pressure plate should be adjusted approximately 0.125" (3.175mm) above the table when the shear blade is in the up position. As the blade is moved downward, the pressure plate should immediately rest against the workpiece and hold it in place.
- To prevent distortion when shearing, snap the handle assembly quickly to pierce the workpiece, then continue with steady even pressure to complete the cut.
- After shearing, metal parts will have a sharp edge on them. These edges may cause cuts when handled. Deburr the workpiece to remove the edge before handling.
- Have the shear blades sharpened by a professional. This will lead to accurate, quality results.
- To avoid rolling over the edge of the sheet metal and pinching it between the two blades, NEVER cut any piece narrower than eight times the thickness of the material.



SHEARING SHEET METAL

⚠ WARNING: Before operating the Baileigh Shear, Brake, Roll make sure it is firmly bolted to a table, bench, or the floor. If it tips over on you, it could cause severe injury or death.

⚠ WARNING: The shearing blades pose an amputation hazard. Make sure no body part or clothing is near the specific hazard. Failure to follow this warning could result in severed or crushed fingers.

⚠ CAUTION: Always wear proper eye protection with side shields, safety footwear, and leather gloves to protect from burrs and sharp edges. When handling large heavy materials make sure they are properly supported. Use Caution and good communication skills between the primary and secondary operator. Both operators should apply even and consistent force to the handlebars during the cut.

1. Adjust the rear stop (#48) to accommodate the length of the cut.
2. Adjust the handlebars within the hubs to full extension to provide as much leverage as possible to assist in the cut.
3. Using the handle assembly, raise the upper blade to the highest position.
4. Have at least one square edge of the material against the side guide or the adjustable rear stop for accurate cuts.
5. Lay the sheet metal on the work apron against the left side guide. Push the sheet under the hold down until it bumps up to the adjustable stop.

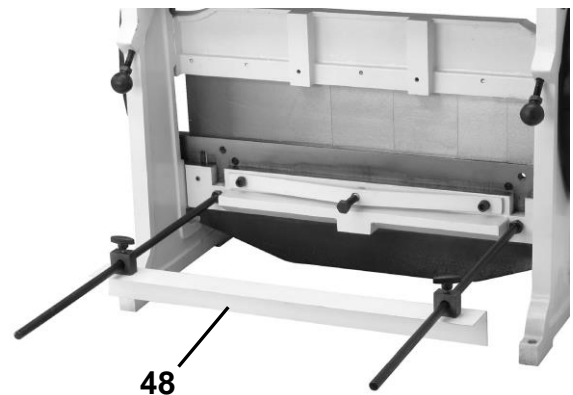



6. In a coordinated fashion, both operators should rotate the handlebar to begin the cut. The shearing action begins at the left side of the piece part and continues to the right until the cut is complete.
 - a. The pressure plate (#63) should make contact with the sheet before the blade (#46) does. If it does not, adjust the two hex bolts (#17) on the pressure plate brackets to lower the pressure plate. When fully open the gap should not exceed 0.125" (3.175mm).
7. Carefully lift the cut piece from the rear of the machine if it does not fall to the tabletop or floor on its own.

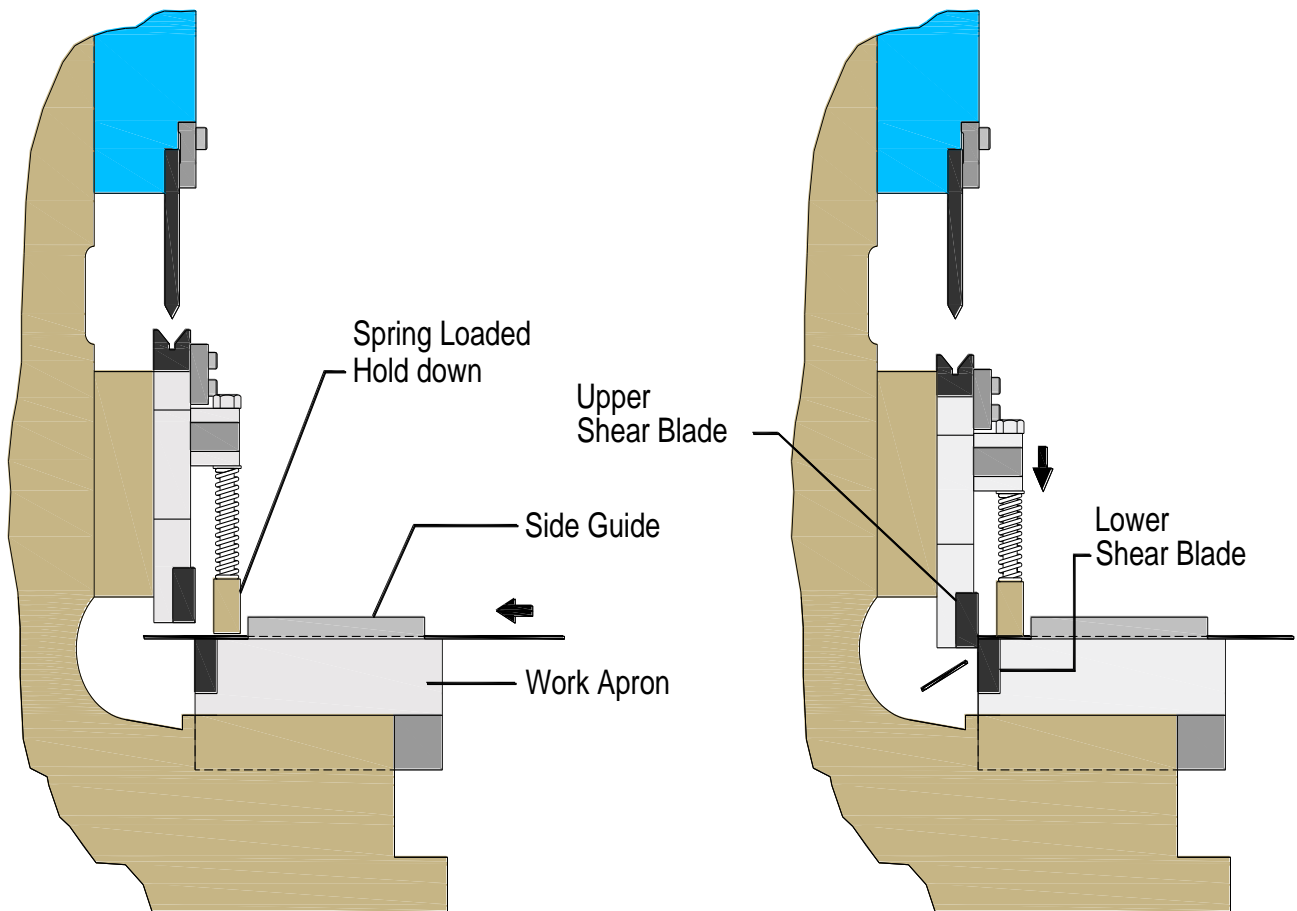
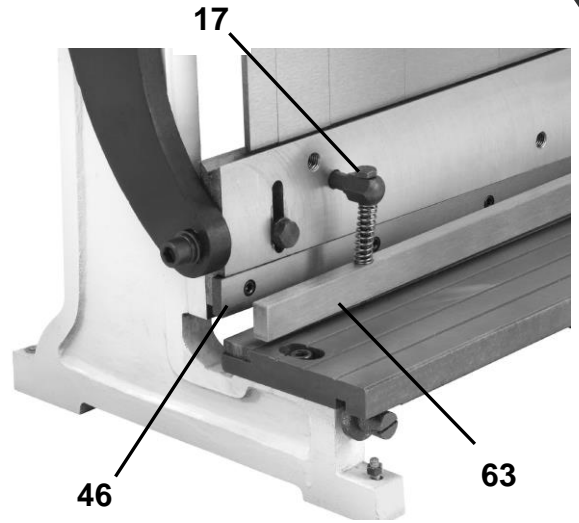



SHEAR BLADE ADJUSTMENTS

To obtain optimum results, shear alignment and shear bow are two conditions which may need to be adjusted depending on the gauge and type of material you want to shear. Shears that are out of adjustment may lead to uneven or ragged cuts.

1. Lower the shear and hold it in position.
2. Measure along the length of the blades; check the gap of the moving blade and the fixed blade with a 0.002" (.05mm) feeler gauge as shown.
 - If the gap is the same along the length of the blades then no further adjustment is needed.
 - If the gap is unequal, proceed to **Step 3**.
 - If you detect a bow in the gap, read the next sub-section on shear bow.
3. Loosen the two cap screws (#13) that hold the table in place.
4. Use a flat blade screwdriver to turn the two adjustment screws (#52) (one on each end of the work apron) until the gap is equal across the length of the blades.
5. Tighten the two table adjustment screws and re-check.
6. While keeping fingers clear of the blades, shear a piece of paper along the full edge of the blade.

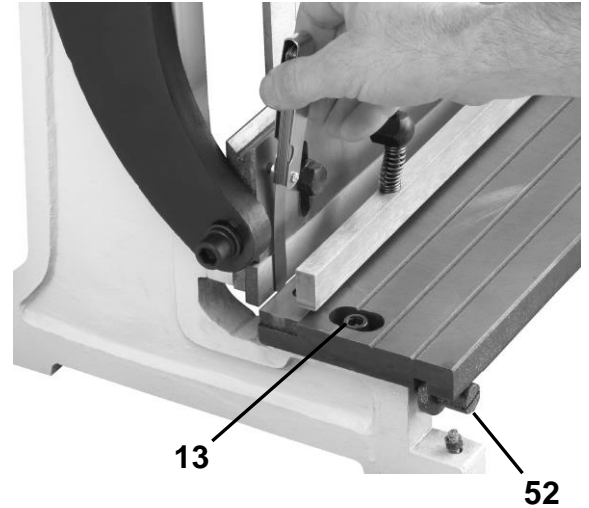

Adjustment Results

- Shear cuts properly along the full length. Reinstall the hold down and follow the adjustment procedure.
- Shear cuts clean at one end but not the other. Repeat steps 2 & 3 above.
- Shear cuts at both ends of the blade but not at the center. Turn the bow nut (A) clockwise (**cw**) until the paper cuts clean at all locations.
- Shear cuts at the center but not the blade ends. Turn the bow nut counterclockwise (**ccw**) until the paper cuts clean the full length.



Once the blade makes a clean cut the whole length, reinstall the hold down and follow the adjustment procedure.



HOLD DOWN ADJUSTMENT

When the shearing cycle starts, the spring loaded hold down pushes on the piece part to secure it. It also helps keep the operator's fingers away from the cutting blades. When adjusted properly there should be no more than 1/4" (6.3mm) of clearance below the hold down to feed the piece part.

How to Adjust the Hold down

1. Turn the handlebar to lower the upper blade completely. Loosen or tighten as needed so there is approximately 1.125" (28.5mm) between the bottom of the bolt head and the flat of the hex stud (#44).
2. Turn the handlebar to raise the blade completely. There should be a 1/4" (6.3mm) gap between the shear table and the hold-down. If not, repeat step 1.

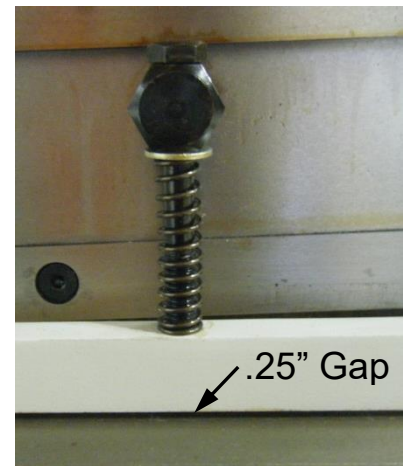
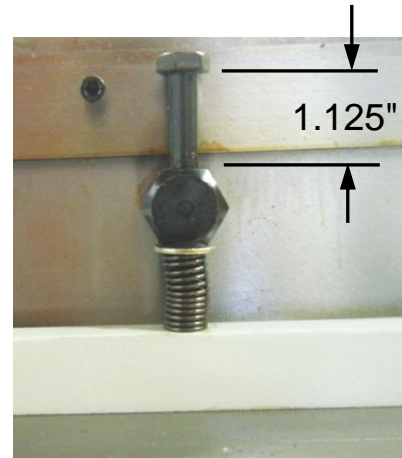



REMOVAL OF BRAKE BLADES FOR CLEANING AND SETUP

Turn the handlebar counterclockwise (**ccw**) to raise the brake blade die until it contacts the brake blades as shown at right. Using a hex wrench, loosen all of the capscrews holding the gib. Now slide the brake blades out, one at a time. Clean the casting seat, the gib, and all of the brake blades with mineral spirits. After drying, lubricate with an anti-rust lubricant.

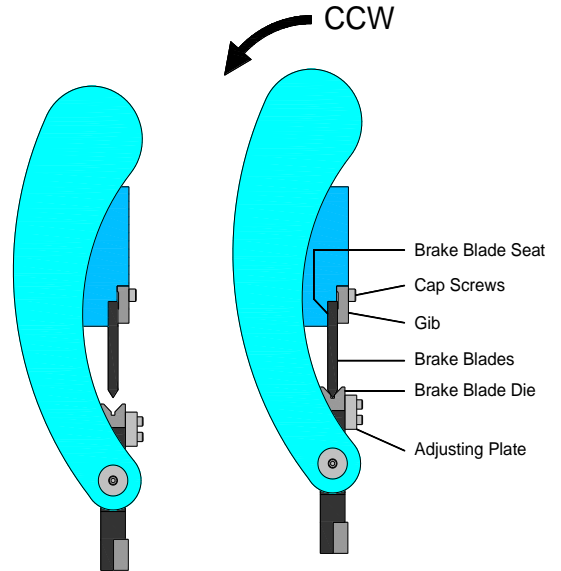

Installing the Brake Blades

Turn the handlebar clockwise (**cw**) to lower the brake blade die. Lay a strip of wood on the brake blade die the full length as shown at right. Start inserting the brake blades. Wide blades to the right and narrow blades to the left when facing the front of the machine. When the brake blades are all in place, turn the handlebar counterclockwise (**ccw**) to raise the brake blade die. When the brake blades are firmly seated in the casting, tighten all of the capscrews on the gib. Now lower the brake blade die and remove the strip of wood.

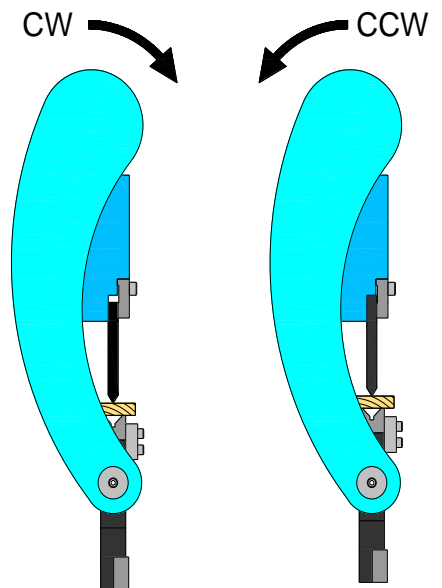



BRAKE OVERVIEW

The Combination SBR has adjustable and removable fingers to offer a wide variety of bending brake options. The brake section is capable of bending up to 20ga. (0.912mm) x 52" (1321mm) wide mild steel sheet.

To start a bend, the operator places a piece of sheet metal on the blade brake die. By turning the handlebar, the brake die is raised up until the tips of the brake blades line up with a line scribed on the sheet metal. If necessary the back gauge can be adjusted to accommodate repeat pieces. By continuing the upward travel of the brake die, the brake blades push the sheet metal down into the "V"-groove of the brake die. The thinner the material the further it will enter the groove for a slight overbend. This is helpful when the material experiences some springback. To remove the piece part, the operator lowers the brake die and removes the piece from the front of the machine.

Bending Allowance

In order to bend sheet metal accurately, you will need to consider the total length of each bend. This is referred to as bend allowance. Subtract the bend allowance from the sum of the outside dimensions of the piece part to obtain the actual overall length or width of the piece. Because of differences in sheet metal hardness, and whether the bend is made with the grain or against it, exact allowances must sometimes be made by trial and error. However bend allowances for general use can be obtained from metal working books or from the Internet.

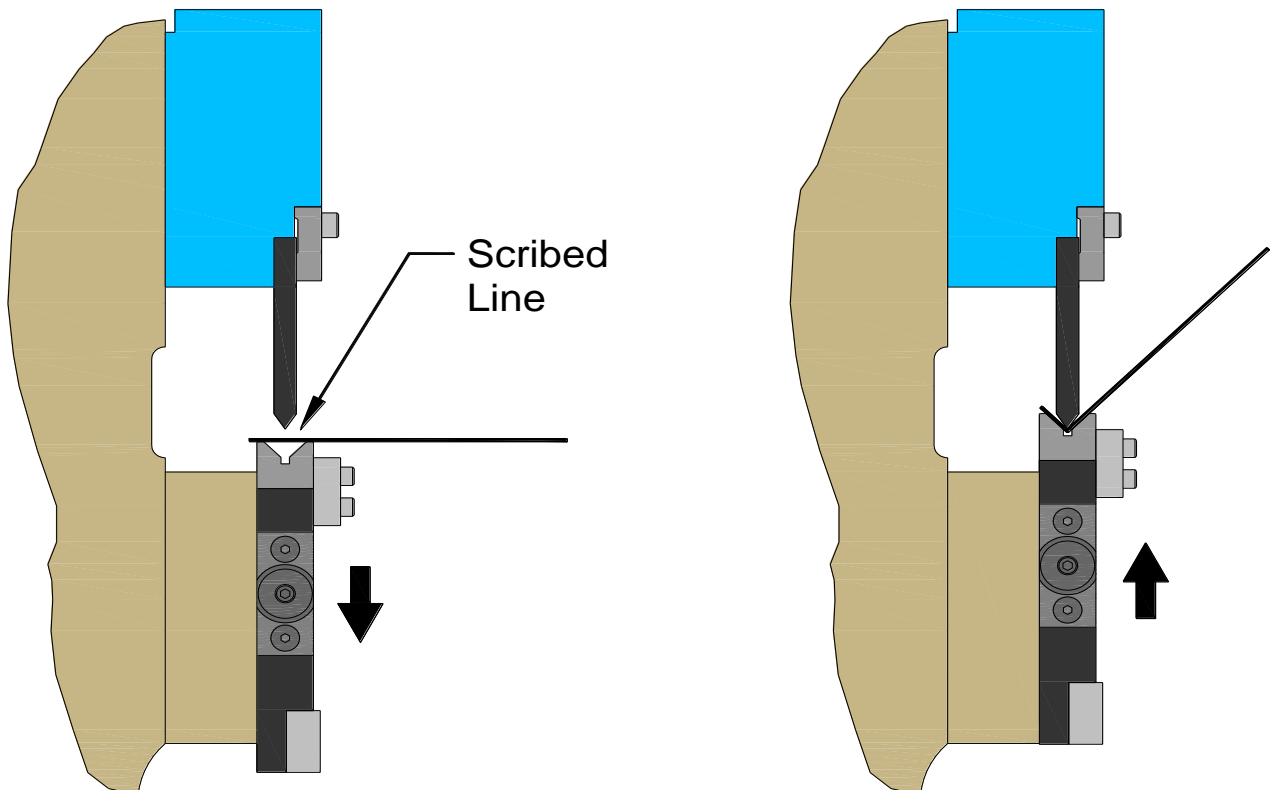



BENDING SHEET METAL

When using the Combination SBR as a manual box and pan brake, the brake blades can be removed and setup to allow all four flanges of the box or pan to be bent upward.

⚠ WARNING: Before operating the Baileigh Shear, Brake, Roll make sure it is firmly bolted to a table, bench, or the floor. If it tips over on you, it could cause severe injury or death.

⚠ WARNING: The bending brake poses a pinching hazard. Make sure no body part or clothing is near the specific hazard. Failure to follow this warning could result in severed or crushed fingers.

⚠ CAUTION: Always wear proper eye protection with side shields, safety footwear, and leather gloves to protect from burrs and sharp edges. When handling large heavy materials make sure they are properly supported. Use Caution and good communication skills between the primary and secondary operator. Both operators should apply even and consistent force to the handlebars during the cut.

Basic Bend Operation

1. Install the back gauge assembly to be on top of the rods as shown.
2. Adjust the stop to the required depth. It can also be mounted on the front of the brake. Or. Scribe a line on the sheet metal to indicate where the bend is to be made.
3. Adjust the handlebars within the hubs to full extension to provide as much leverage as possible to assist in the cut.
4. Using the handle assembly, raise the fingers on the brake until there is enough gap to fit the work piece.
5. Make sure the material is against the back stop or that the scribe mark is lined up to where the brake blade will come down.





6. While the sheet metal is being held firmly, both operators should rotate the handlebar to make the bend to the desired angle.
7. Raise the brake blade die and remove the piece part.



Note: The brake die is designed to bend material up to 90°.

Adjust the fingers for box and pan bending:

1. Place a thin and flat piece of spacer material (**A**) over the notch of the brake die. This flat surface will help you obtain equal finger length.
2. With the handle assembly, lower the fingers so they are just touching the top of the spacer on the brake die.
3. Loosen, but do not remove, the six cap screws (**#20**).
4. Slide the fingers horizontally to the desired position or rearrange them to get the desired width combination for your project.
5. Using the handle assembly, lower the fingers to apply light pressure. Check to make sure each finger has continuous contact with the spacer.
6. Tighten the six cap screws.

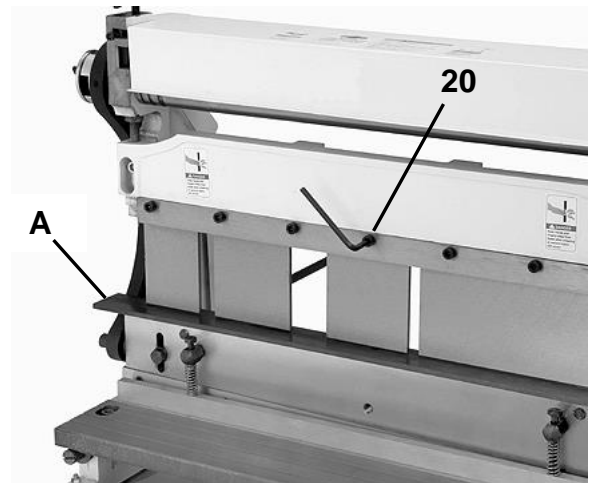



SLIP ROLL OVERVIEW

The slip roll section can be used to roll up to 20ga. (0.912mm) x 52" (1321mm) wide mild steel. It consists of 3 hardened rolls. The rear roll is adjustable to control the radius of the piece part as it is being formed. The closer the rear roll is brought to the front upper roll, the tighter the radius. The two front gear driven rolls pinch the material and pull it against the rear roll, forcing it up towards the front upper roll. The top front roll has two adjustment knobs, one on each end of the machine, to control the upper and lower roller spacing for different material thicknesses. When removing the formed piece part, the top front roll can be slipped out.

- When the slip roll section is not being used, the operator can cover the rolling mechanism with the formed steel pivoting cover / guard.
- The rear roll can be adjusted to a raised or tilted position on one end to roll cones or left flat to roll cylinders or arcs.
- Located on the end of the upper and lower rolls are three wire or forming grooves. These can be used for forming small diameter tubing or wire into rings or curved shapes.
- To prolong the life of the rolls, always keep them clean and well lubricated. Remove burrs from the edges of any sheet metal being processed through the rolls.
- **DO NOT** exceed the rated capacity on this slip roll. It has been tested at the factory to roll 20ga. (0.912mm) x 52" (1321mm) wide mild steel.
- Because material springback varies with the kind of material being formed, only by test forming several pieces can the correct adjustments be made.

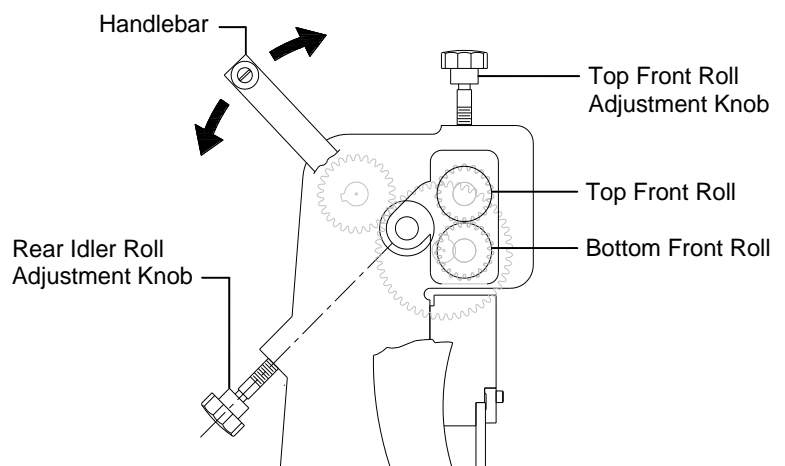

CAUTION: When handling large piece parts, you may require assistance in handling the piece as it exits the rolls. Failure to adequately support the piece part may result in the piece falling and causing bodily injury.



OPERATING THE SLIP ROLL

⚠ WARNING: Before operating the Baileigh Shear, Brake, Roll make sure it is firmly bolted to a table, bench, or the floor. If it tips over on you, it could cause severe injury or death.

⚠ WARNING: Rolling poses a pinching hazard. Make sure no body part or clothing is near the specific hazard. Failure to follow this warning could result in severed or crushed fingers.

⚠ CAUTION: Always wear proper eye protection with side shields, safety footwear, and leather gloves to protect from burrs and sharp edges. When handling large heavy materials make sure they are properly supported. Use Caution and good communication skills between the primary and secondary operator. Both operators should apply even and consistent force to the handlebars during the cut.

Determining Length of Material

LENGTH OF MATERIAL necessary to form the desired size circle is the first consideration in circle forming. To determine the approximate length of material needed use the formula: $C = I \times D$, Where **C** is the circumference, **I** is the value of π or 3.1416, and **D** is the diameter. For example, to find the length of material (C or Circumference) to form a 4" (101.6mm) diameter circle, multiply (3.1416 x 4). The result is 12.5664 or the approximate length of material needed. Cut a few pieces of material to this length for test forming. Material may have to be lengthened or shortened depending upon results of the test forming run.

Pre-Bending and Finish Rolling

PRE-BENDING is the operation where the ends of the material are bent to the same radius as that of the finished piece. This principle is used to get the best results in full circle bending.

Before bending, follow these steps:

- Clean the material and rolls of any dust or grease.
- Make sure the edges of the piece part are free of chips and burrs.
- Check that the material is flat.
- Have a template of the finished diameter to compare with.
- Always work in the center of the rolls.

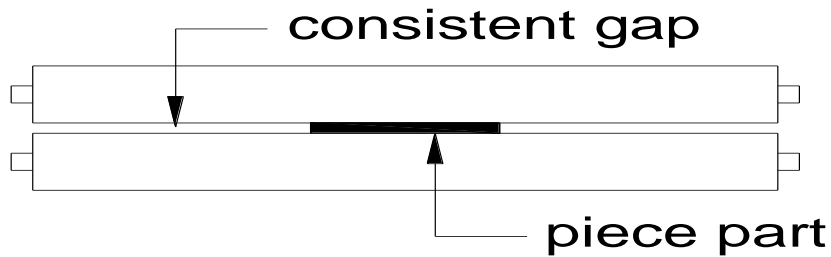

Rolling Operation

1. Back off the idler roll by turning the two adjustment bolts counterclockwise (**ccw**) as in view "A" below.
2. Unscrew the top roll adjustment bolts until there is enough gap between the top and bottom rolls to allow the piece part to fit between.
3. Rotate the handlebar to advance the piece part about 1" (25.4mm) beyond the rolls.
4. Tighten the top roll adjustment bolts to hold the piece part firmly.
5. Raise the idler roll enough to get the material started in an upward direction against the top front roll as shown in view "B".

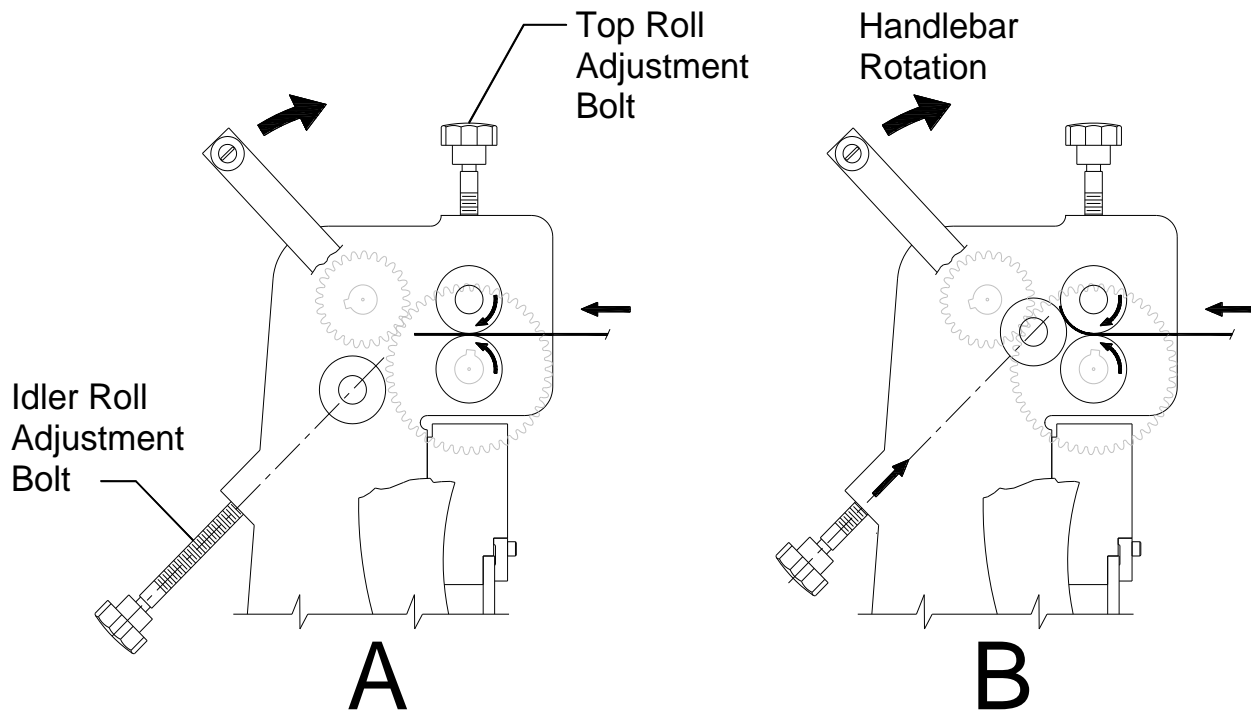

6. Rolling the initial edge slightly will give it a pre-bend.
7. Back the piece out, turn the piece part and repeat the sequence for the other end. See view "C" below.
8. Now that you have a pre-bend on both ends, it is time to roll the final diameter.



- Back down the rear idler roll and start rolling the piece forward and reverse as shown in view "D".
- Start raising the idler roll gradually and continue rolling the piece forward and reverse until you have reached the finished diameter.



Note: *To achieve a cone configuration, adjust the idler roll on one end only.*

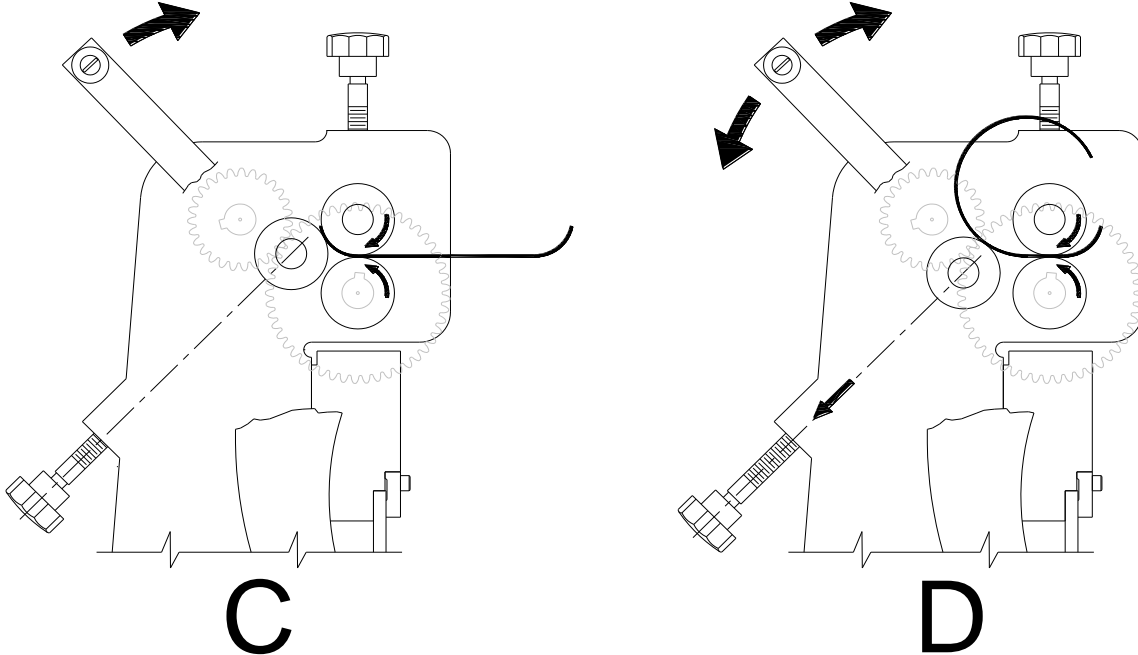

⚠ CAUTION: Have an assistant support the top roll when removing finished cylinders from the top roll. Failure to adequately support the top roll may result in the roll falling, and causing personal injury.

- To remove a finished piece part from the top roll, loosen both top roll adjustment bolts (#24).
- With the help of an assistant, lift the left end of the top roll, up and out, keeping the right end gears meshed as much as possible. The other person will slide the finished cylinder off. The roll is heavy, so **DO NOT** attempt this alone.

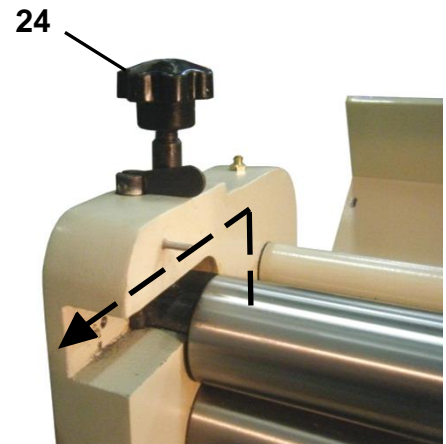



Rolling Round Shapes

There are three wire or forming grooves located on the right end of the upper and lower rolls. They can be used to form solid wire, rods, and small tubing.

To make rings, follow the "Determining Length of Material" procedure to calculate the actual length. Then proceed with the rolling operation.

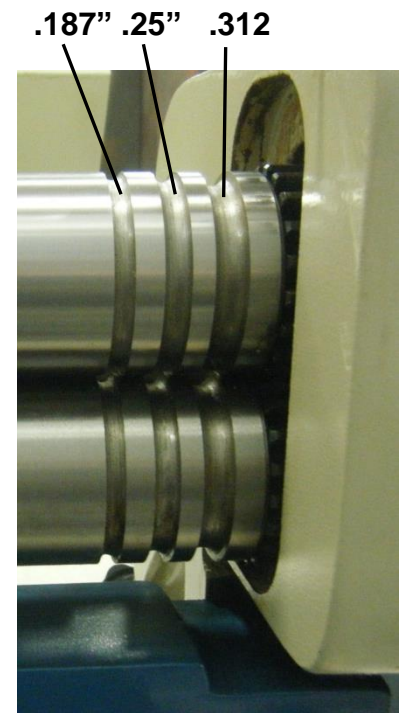



BENDING ALLOWANCE

In order to bend sheet metal accurately, you will need to consider the total length of each bend. This is referred to as bend allowance. Subtract the bend allowance from the sum of the outside dimensions of the piece part to obtain the actual overall length or width of the piece. Because of differences in sheet metal hardness, and whether the bend is made with the grain or against it, exact allowances must sometimes be made by trial and error. However bend allowances for general use can be obtained from metal working books or from the Internet.

UNDERSTANDING SPRINGBACK

Springback, also known as elastic recovery, is the result of the metal wanting to return to its original shape after undergoing compression and stretch. After the bending leaf is removed from the metal and the load is released, the piece part relaxes, forcing the bent portion of the metal to return slightly to its original shape. The key to obtaining the correct bend angle is to over bend the metal a little and allow it to spring back to the desired angle. All metals exhibit a certain amount of spring back.

MATERIAL SELECTION

 **CAUTION:** It must be determined by the customer that materials being processed through the machine are NOT potentially hazardous to operator or personnel working nearby.

When selecting materials keep these instructions in mind:

- Material must be clean and dry. (without oil)
- Material should have a smooth surface so it processes easily.
- Dimensional properties of material must be consistent and not exceed the machine capacity values.
- Chemical structure of material must be consistent.
- Buy certificated steel from the same vendor when possible.



LUBRICATION AND MAINTENANCE

⚠ WARNING: Maintenance should be performed on a regular basis by qualified personnel.
Always follow proper safety precautions when working on or around any machinery.

Check for the following conditions and repair or replace when necessary:

- Check daily for any unsafe conditions and fix immediately.
- Check that all nuts and bolts are properly tightened.
- On a weekly basis clean the machine and the area around it.
- Lubricate gears, bushings, threaded components and sliding devices.
- Apply rust inhibitive lubricant to all non-painted surfaces.
- Loose mounting bolts.
- Chipped brake fingers.
- Dull or chipped shear blades.
- Inadequate lubrication.
- Any other condition that could hamper the safe operation of this machine.

Apply multi-purpose grease

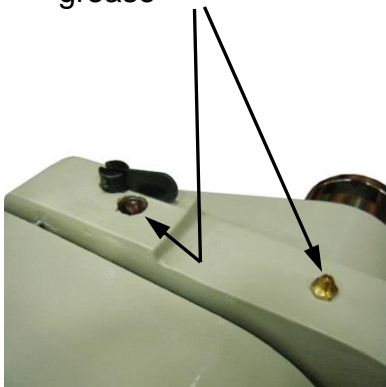

Brush a light coat of grease on the gear teeth. Turn the handlebar to disperse the grease.

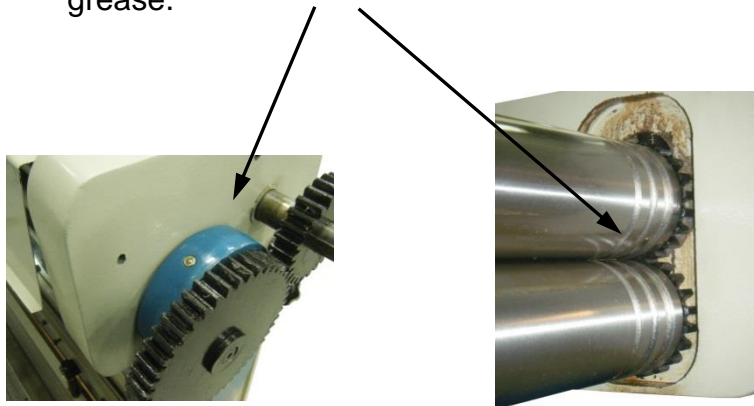

Note: Proper maintenance can increase the life expectancy of your machine.



SLIP ROLL MAINTENANCE

Every (6) months remove and lubricate the roller bushings.

1. With the aid of an assistant carefully remove the top front roll. To do so, back off both top roll adjustment bolts, and rotate the roll release pin (left side of roll), 90°. Be careful not to damage the roll.
2. Remove both bushings from the ends of the roll.
3. With mineral spirits, wipe all old grease from the bushings, gears, roller end shafts, and machined pockets that the bushings rest on.
4. After the parts have dried, lubricate them sufficiently with multi-purpose grease.
5. Apply some 10W30 or equivalent oil into the bushings of the bottom front roll.
6. Lower the idler roll by turning the (2) idler adjustment bolts counterclockwise (**ccw**). This will give you access to apply oil to the bushings.
7. Remove the idler adjustment bolts and clean the threads. Lubricate with oil and re-install.

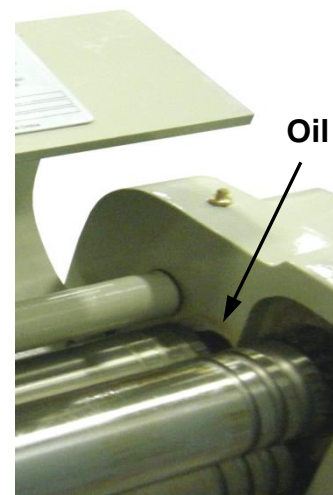
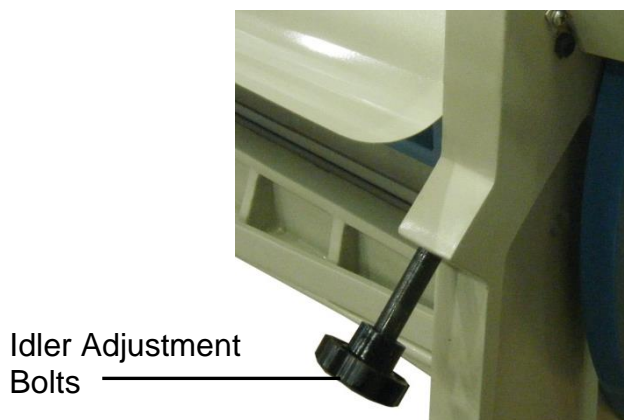
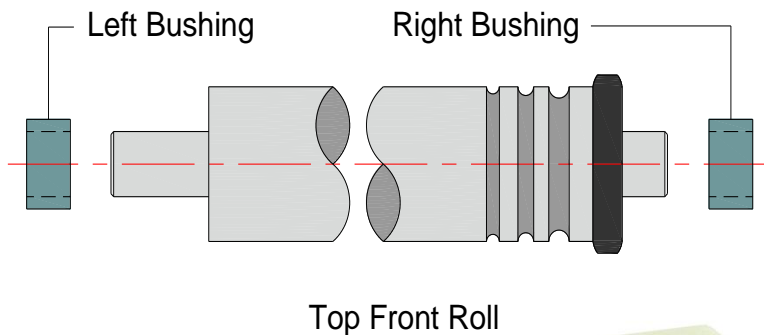



BRAKE ALIGNMENT

⚠ WARNING: The bending brake poses a pinching hazard. Make sure no body part or clothing is near the specific hazard. Failure to follow this warning could result in severed or crushed fingers.

On occasion, it may become necessary to realign the brake blades and the brake die. Follow the procedure below:

1. The first thing to do is clean and then deburr the brake blades and the V-groove of the brake die.
2. Make sure all brake blades are tight and seated properly.
3. Place a straight piece of .5" to .75" (12.7 to 19mm) diameter tubing (approx.) 42" (1067mm) long in the brake die "V"- groove.
4. Raise the blade die until the side of the pipe lightly contacts the brake blades.
5. From one end to the other, visually check for consistent contact between the pipe and the blades.
6. If you notice a gap at one end of the brake, loosen the (2) carriage lock capscrews at that end, and adjust the jack bolt until the brake blades just touch the pipe.
7. Tighten both capscrews and remove the pipe.
8. After cycling the brake a few times, recheck the alignment.

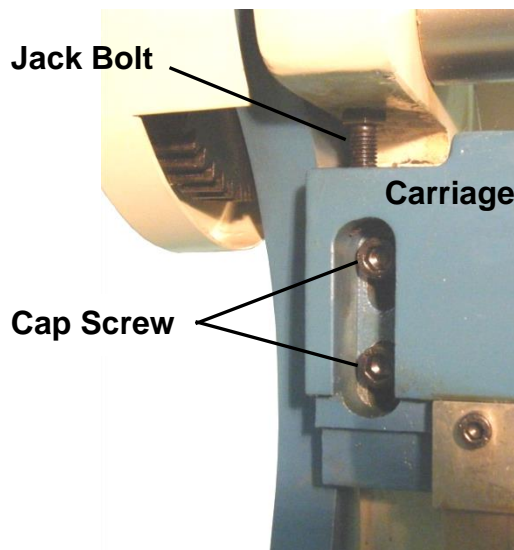
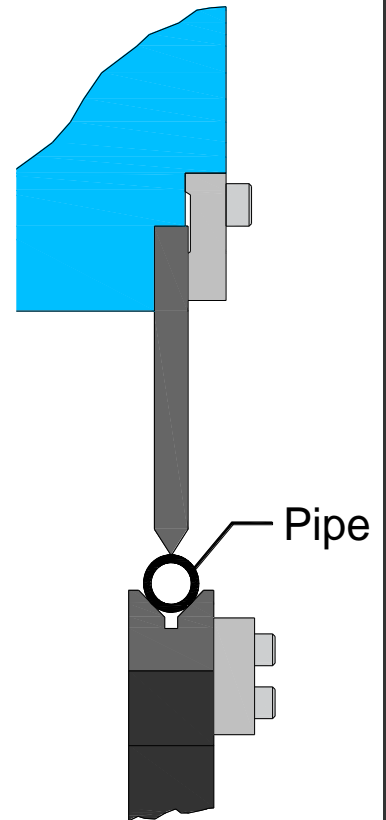



REPLACING THE SHEAR BLADE

⚠ WARNING: The shear blade poses an amputation hazard. Make sure no body part or clothing is near the specific hazard. Failure to follow this warning could result in severed or crushed fingers.

When the blade edge has been ground to the point that the blade gap can no longer be set correctly, replace the blades as a set. Contact Baileigh Industrial for replacement blades.

Replace Blades

1. Remove the material hold down by unscrewing the bolts (#70) from the hold down bar (#41). **Material Hold Down** → 
2. Raise the shearing blade assembly to the top of its stroke and secure either by blocking the frame or tying off the handlebar. **MAKE SURE** it is secure to avoid accidental shearing.
3. Remove the eight flathead screws holding on the upper blade (#40) and remove it from the movable blade (#39). When handling the blade always wear leather gloves to protect your hands.
4. Grind or replace the blade. Replace the flat head screws and tighten securely.
5. To replace the lower blade you must work from the other side (rear) of the machine.
6. Remove the eight flathead screws holding on the lower blade (#40) and remove it from the shear table (#2). When handling the blade always wear leather gloves to protect your hands.
7. Grind or replace the blade. Replace the flat head screws and tighten securely.
8. While keeping fingers clear of the blades, shear a piece of paper all along the full length of the blades.

Shear Results

- Shear cuts properly along the full length. Reinstall the hold down and follow the adjustment procedure.
- Shear cuts poorly at the blade ends. Follow the blade adjustment procedure.
- Shear cuts all but one or two locations in the center. Loosen the flat head screw at the location where the cut is poor. Apply a piece of shim material between the blade and the backup and then retighten the screw. Check cut again.



PARTS IDENTIFICATION DRAWING - A

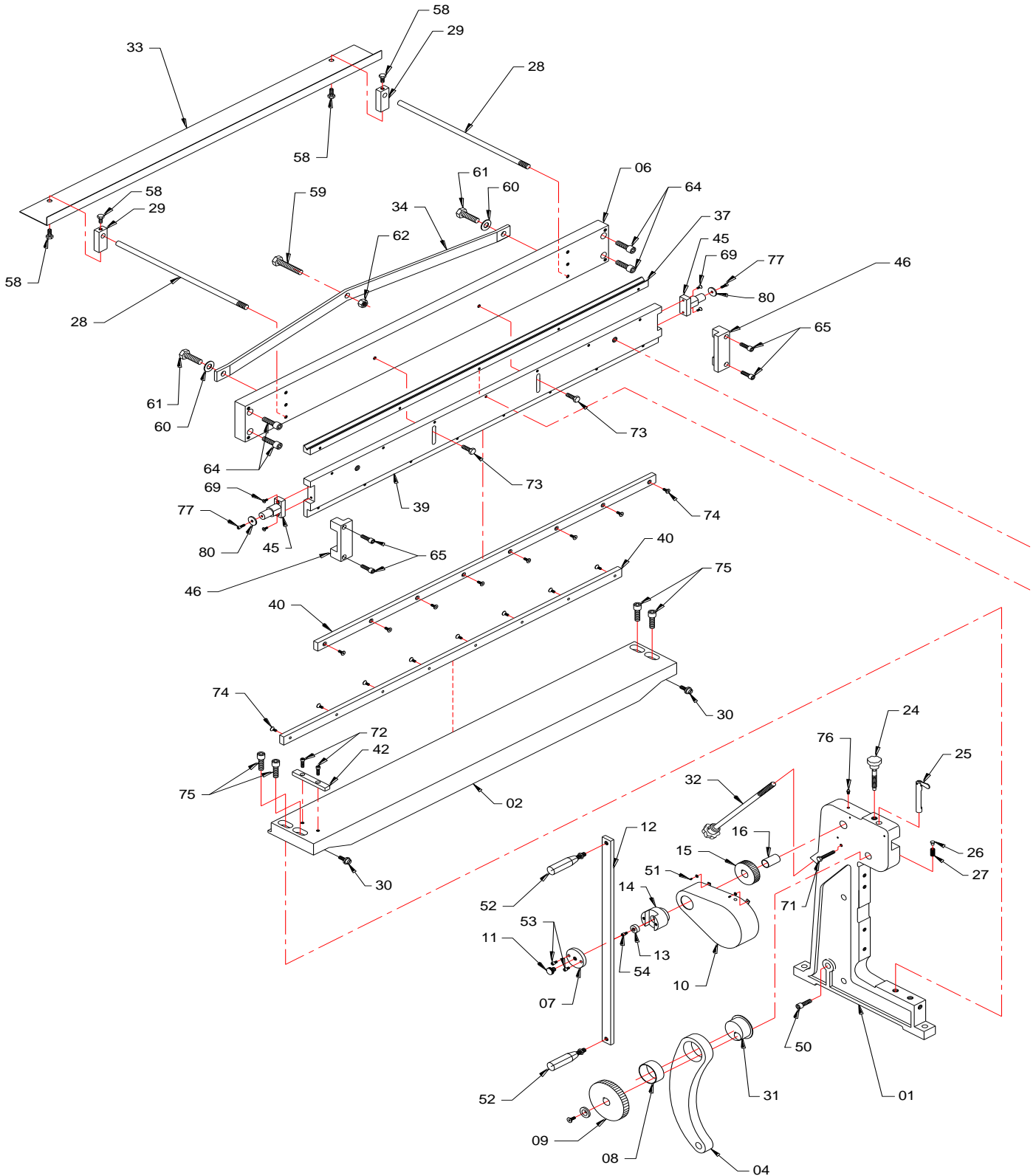



PARTS IDENTIFICATION DRAWING - B

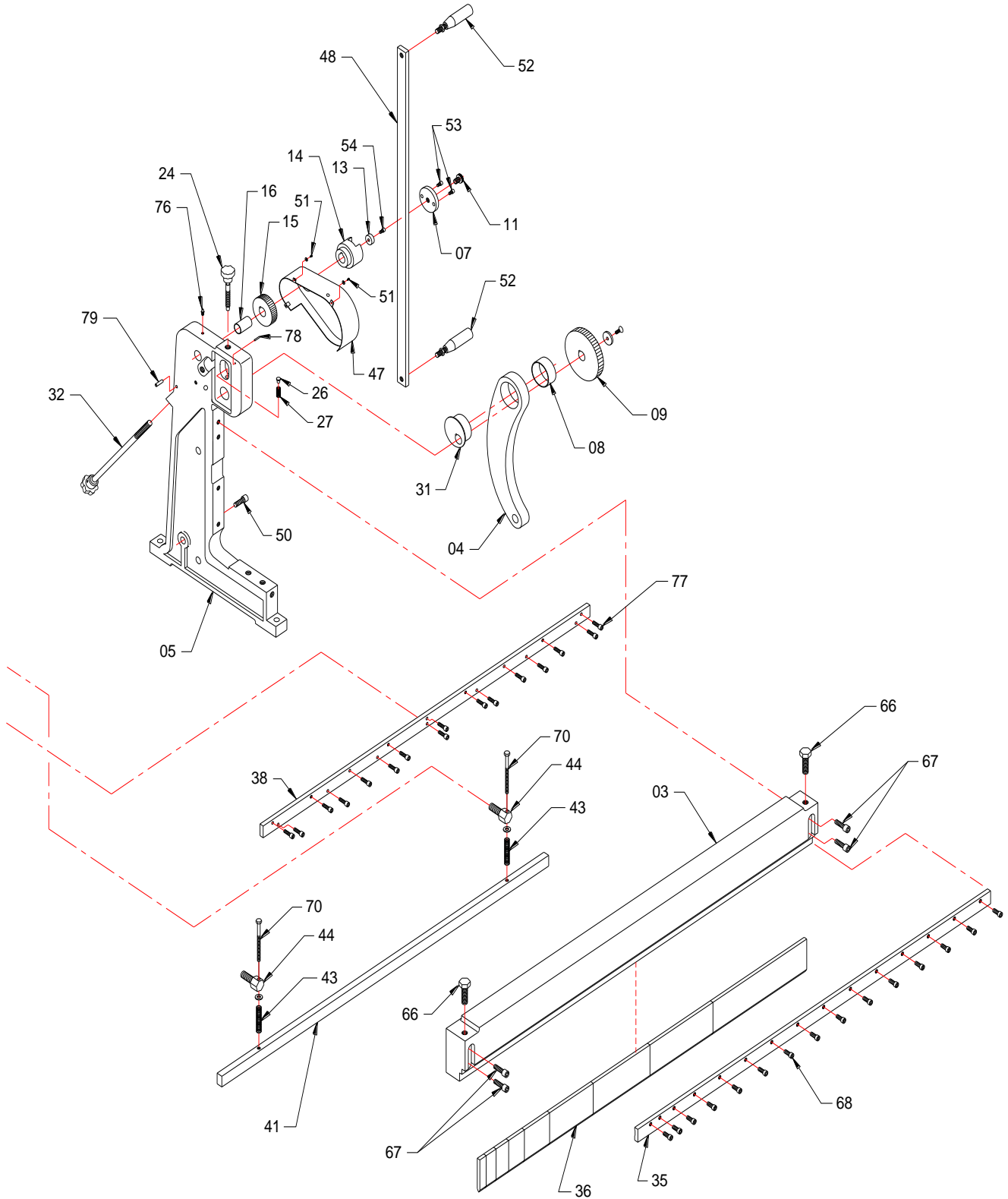



PARTS IDENTIFICATION DRAWING - C

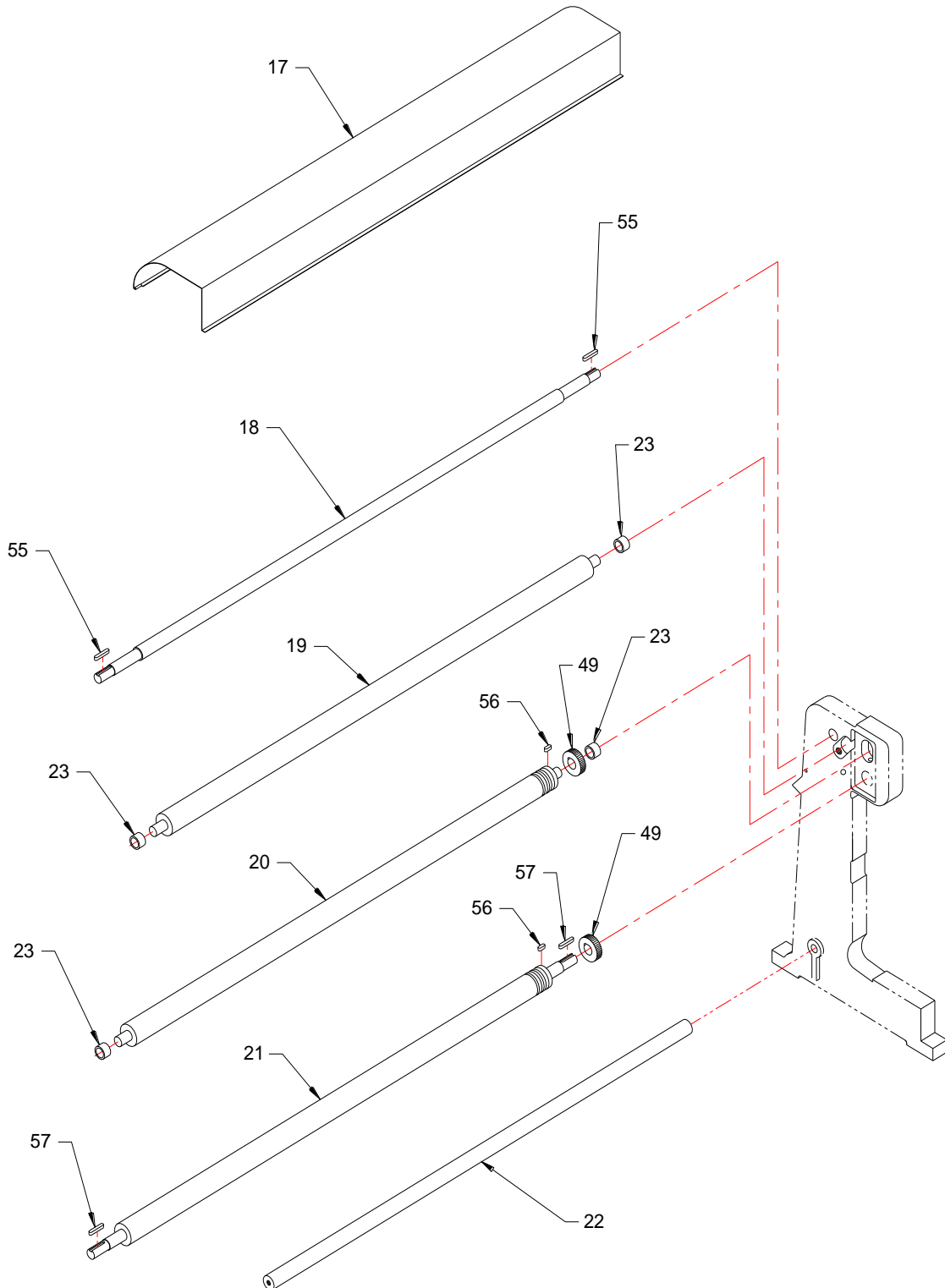



Parts List

Item	Item	Description	Qty.
01	SBR5220-01	Left Side Member	1
02	SBR5220-02	Shear Table	1
03	SBR5220-03	Crossbeam	1
04	SBR5220-04	Crank Arm	2
05	SBR5220-05	Right Side Member	1
06	SBR5220-06	Connector	1
07	SBR5220-07	Cover	2
08	SBR5220-08	Bushing	2
09	SBR5220-09	Large Gear	2
10	SBR5220-10	Left Gear Cover	1
11	SBR5220-11	Threaded Knob	2
12	SBR5220-12	Short Handlebar	1
13	SBR5220-13	Pressing Cover	2
14	SBR5220-14	Handle Seat	2
15	SBR5220-15	Small Gear	2
16	SBR5220-16	Bushing	2
17	SBR5220-17	Roll Cover	1
18	SBR5220-18	Transmission Shaft	1
19	SBR5220-19	Rear Shaft	1
20	SBR5220-20	Front Upper Shaft	1
21	SBR5220-21	Front Lower Shaft	1
22	SBR5220-22	Connect Pipe	1
23	SBR5220-23	Bushing	4
24	SBR5220-24	Top Roll Adjustment Bolt	2
25	SBR5220-25	Top Roll Lock Pin	1
26	SBR5220-26	Pin	2
27	SBR5220-27	Spring	2
28	SBR5220-28	Long Screw	2
29	SBR5220-29	Stand Die	2
30	SBR5220-30	Table Adjustment Screw	2
31	SBR5220-31	Eccentric Plate	2
32	SBR5220-32	Rear Adjustment Knob	2
33	SBR5220-33	Back Gauge	1



Item	Item	Description	Qty.
34	SBR5220-34	Bending Bar	1
36	SBR5220-36	Brake Blade (Assorted Sizes)	1
37	SBR5220-37	Brake Blade Die	1
38	SBR5220-38	Adjusting Plate	1
39	SBR5220-39	Movable Blade Mount	1
40	SBR5220-40	Blade-Upper	2
41	SBR5220-41	Hold Down	1
42	SBR5220-42	Side Guide	1
43	SBR5220-43	Hold Down Spring	2
44	SBR5220-44	Hex Stud	2
45	SBR5220-45	Pin Seat	2
46	SBR5220-46	Left And Right Press Block	2
47	SBR5220-47	Right Gear Cover	1
48	SBR5220-48	Long Handlebar	1
49	SBR5220-49	Small Roll Gear	2
50	SBR5220-50	Socket Capscrew 12 x 55mm	2
51	SBR5220-51	Machine Screw 6 x 16mm	6
52	SBR5220-52	Handle	4
53	SBR5220-53	Socket Capscrew 6 x 12mm	4
54	SBR5220-54	Socket Capscrew 6 x 14mm	2
55	SBR5220-55	Flat Key	2
56	SBR5220-56	Flat Key	2
57	SBR5220-57	Flat Key	2
58	SBR5220-58	Hex Bolt 12 x 20mm	2
59	SBR5220-59	Hex Bolt 16 x 80mm	1
60	SBR5220-60	Washer 16mm	2
61	SBR5220-61	Hex Bolt 16 x 40mm	2
62	SBR5220-62	Hex Nut 16mm	1
64	SBR5220-64	Socket Capscrew 16 x 60mm	4
65	SBR5220-65	Socket Capscrew 12 x 40mm	4
66	SBR5220-66	Hex Bolt 12 x 32mm	2
67	SBR5220-67	Socket Capscrew 12 x 65mm	4
68	SBR5220-68	Socket Capscrew 8 x 25mm	15
69	SBR5220-69	Socket Capscrew 8 x 30mm	4
70	SBR5220-70	Hex Bolt 10 x 114mm	2



Item	Item	Description	Qty.
71	SBR5220-71	Hex Bolt 8 x 65mm	2
72	SBR5220-72	Socket Capscrew 6 x 12mm	2
73	SBR5220-73	Hex Bolt 10 x 40mm	2
74	SBR5220-74	Flt. Hd. Soc. Capscrew 8 x 25mm	16
75	SBR5220-75	Socket Capscrew 16 x 45mm	4
76	SBR5220-76	Grease Fitting	2
77	SBR5220-77	Socket Capscrew 6 x 20mm	2
78	SBR5220-78	Pin	2
79	SBR5220-79	Pin	2
80	SBR5220-80	Washer	2



TROUBLESHOOTING

Shear Operation

FAULT	PROBABLE CAUSE	REMEDY
Can't shear material	Improper blade gap distance, exceeding machine capacities	Widen gap for thicker material
Cuts are not square.	Blade gap unequal across length, Too much bow in blade, Inadequate hold down pressure.	Adjust blade gap to be equal across length, Adjust blade bow, Adjust hold down gap.
Poor quality of cuts, ripping./ or tearing	Dull blades, Poor blade gap set-up, Loose blade	Replace or sharpen blades, Adjust blade gap, Remove blade, clean mounting.

Brake Operation

FAULT	PROBABLE CAUSE	REMEDY
Heavy resistance during bends	Exceeding machine capacities.	Use materials within machine capabilities
Bend radius is not consistent	Brake blades and die are not aligned.	Adjust brake alignment.
Brake blade points are chipping.	Brake blades and die are not aligned.	Adjust brake alignment.
Piece part shows scoring marks after bend.	Brake blades or die has scratches.	Polish out scratches,

Slip Roll Operation

FAULT	PROBABLE CAUSE	REMEDY
Slip Roll creates cones instead of cylinders.	Rolls are not parallel to each other.	Adjust the rear roll to be parallel to the top roll.
A noticeable crease forms in the piece part.	Excessive pressure applied to one spot.	Reduce the radius and make the bend in several passes.
Piece part is pitted.	Material sheet is dirty or roll is damaged.	Clean material, polish nicks in roller.



NOTES



BAILEIGH INDUSTRIAL HOLDINGS LLC
1625 DUFEK DRIVE MANITOWOC, WI 54220
PHONE: 920. 684. 4990 FAX: 920. 684. 3944
www.baileigh.com